

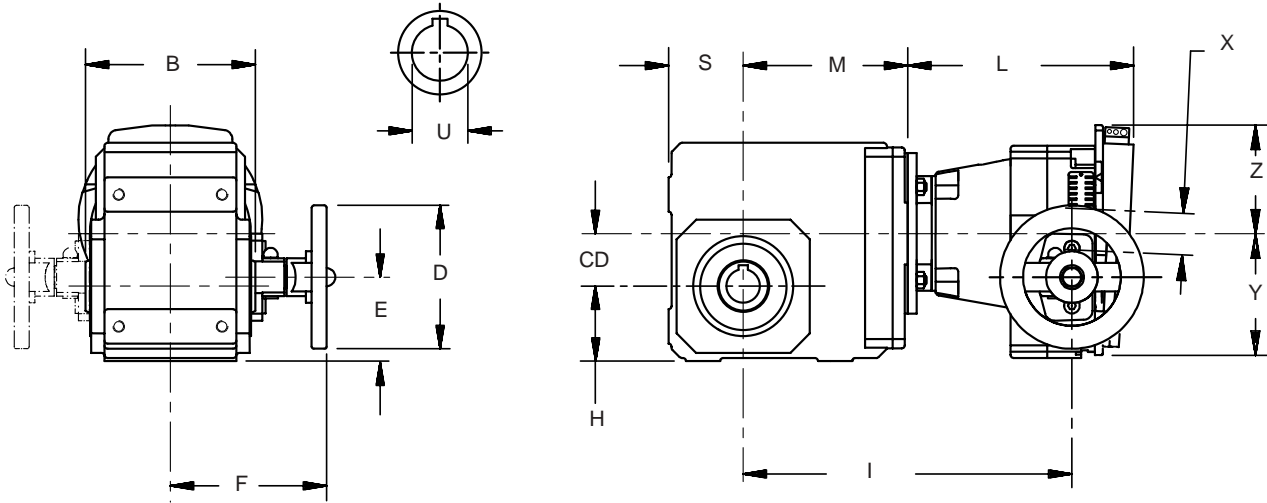

"K" Series – MGS® Adjustable Speed Drives Dimensional Data



Drawing for Units
K102AB — K403AB

Table No. 1
"K" Series – Basic Unit Dimensions (Inches)
"B" Housing Style

Base Module	B	H	S	U
K102	4.72	2.36	2.36	1.0000
K202	5.83	2.56	2.56	1.1875
K302/K303	6.30	2.95	2.95	1.3750
K402/K403	7.40	3.54	3.54	1.5000
K513/K514	7.87	6.30	3.94	2.0000
K613/K614	8.46	7.48	4.72	2.0000
K713/K714	9.53	8.35	4.92	2.3750
K813/K814	11.81	10.43	5.71	2.7500
K913/K914	13.78	12.40	7.09	3.2500
K1013/K1014	16.14	14.76	8.86	4.0000

Table No. 2
"K" Series – Basic Unit Dimensions (Inches) "B" Housing Style

ComTrac Part No.	NEMA C-Flange	D	F	L	X	Y	Z
TD270K050	56C	4.92	5.67	7.87	2.09	5.55	4.41
TD270K140	143/145TC	4.92	5.67	7.87	2.09	5.55	4.41
TD370K140	143/145TC	4.92	5.91	8.50	2.17	5.67	4.37
TD470K180	182/184TC	6.30	6.81	8.94	2.80	7.20	5.59
TD570K180	182/184TC	7.87	8.31	11.89	3.11	8.11	6.30
TD670K210	213/215TC	7.87	9.17	12.17	3.86	9.02	7.13
TD760K210	213/215TC	9.84	9.72	14.25	4.29	9.37	7.68

Table No. 3
"K" Series – "B" Housing Style – Approximate Weight (lbs.)

Part Number	K102	K202	K302	K303	K402	K403	K513	K514	K613	K614	K713	K714	K813	K814	K913	K914	K1013	K1014
TD270K050⁽²⁾	64	73	100	106	—	133	—	142	—	210	—	267	—	—	—	—	—	—
TD370K140	82	91	118	124	144	151	157	160	—	228	—	285	—	—	—	—	—	—
TD470K180	—	99	126	—	152	—	165	—	229	—	280	293	—	390	—	589	—	—
TD570K180	—	—	155	—	181	—	184	—	258	—	309	322	397	410	—	618	—	—
TD670K210	—	—	—	—	223	—	236	—	300	—	351	—	439	—	638	660	—	1123
TD760K210	—	—	—	—	—	—	—	—	364	—	415	—	503	—	702	—	1107	1187

⁽²⁾Also available as TD270K140 for a NEMA 143TC frame motor.

See the MGS catalog for dimensions not shown.

"K" Series – MGS® Adjustable Speed Drives Dimensional Data

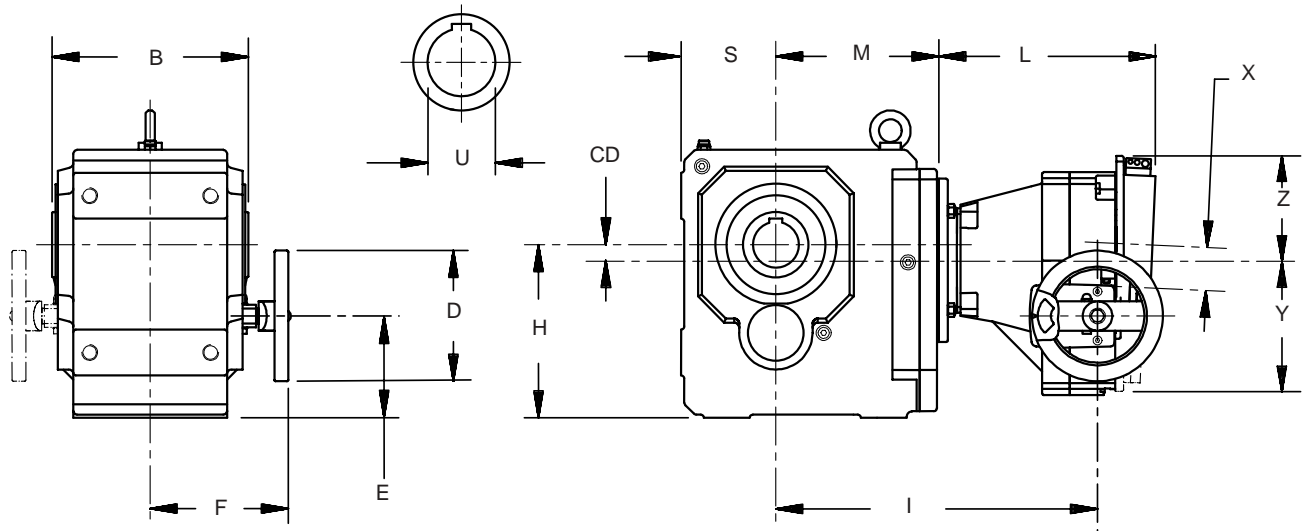

Drawing for Units
K513AB — K1014AB

Table No. 3 "K" Series – Basic Unit Dimensions (Inches) – "B" Housing Style

Base	CD	TD270K050 ⁽¹⁾			TD370K140			TD470K180			TD570K180			TD670K210			TD760K210		
		E	I	M	E	I	M	E	I	M	E	I	M	E	I	M	E	I	M
K102	1.42	2.20	7.87	5.04	1.73	8.50	5.04	—	—	—	—	—	—	—	—	—	—	—	—
K202	1.81	2.80	11.97	5.79	2.32	12.64	5.79	1.17	12.76	5.87	—	—	—	—	—	—	—	—	—
K203	1.81	—	—	—	—	—	—	—	—	—	—	—	—	—	—	—	—	—	—
K302	2.07	3.44	12.76	6.57	2.97	13.43	6.57	2.42	13.54	6.65	1.67	16.18	6.65	—	—	—	—	—	—
K303	.63	2.01	14.45	8.27	1.54	15.12	8.27	—	—	—	—	—	—	—	—	—	—	—	—
K402	2.36	—	—	—	3.86	14.21	7.36	3.31	14.33	7.44	2.56	16.97	7.44	2.36	17.28	7.56	—	—	—
K403	.91	2.87	15.24	9.06	2.40	15.91	9.06	—	—	—	—	—	—	—	—	—	—	—	—
K513	.59	—	—	—	3.66	13.62	6.77	3.11	13.74	6.85	2.36	16.38	6.85	2.17	16.69	6.97	—	—	—
K514	.59	4.13	14.65	8.46	3.66	15.31	8.46	—	—	—	—	—	—	—	—	—	—	—	—
K613	.71	—	—	—	—	—	—	4.17	14.49	7.60	3.43	17.13	7.60	3.23	17.44	7.72	3.23	19.88	8.27
K614	.71	5.20	15.39	9.21	4.72	16.06	9.21	—	—	—	—	—	—	—	—	—	—	—	—
K713	.79	—	—	—	—	—	—	4.96	15.59	8.70	4.21	18.23	8.70	4.02	18.54	8.82	4.02	20.94	9.33
K714	.79	5.98	16.54	10.35	5.51	17.20	10.35	4.96	18.03	11.14	4.21	20.67	11.14	—	—	—	—	—	—
K813	.94	—	—	—	—	—	—	—	—	—	6.14	19.25	9.72	5.94	19.53	9.80	5.94	21.93	10.31
K814	.94	—	—	—	—	—	—	6.89	19.02	12.13	6.14	21.65	12.13	—	—	—	—	—	—
K913	.98	—	—	—	—	—	—	—	—	—	—	—	—	7.87	21.30	11.57	7.87	23.70	12.09
K914	.98	—	—	—	—	—	—	8.82	20.79	13.90	8.07	23.43	13.90	7.87	24.09	14.37	—	—	—
K1013	1.10	—	—	—	—	—	—	—	—	—	—	—	—	—	—	—	10.11	14.25	15.43
K1014	1.10	—	—	—	—	—	—	—	—	—	—	—	—	10.11	12.16	17.72	10.11	14.25	18.70

⁽¹⁾ Also available for a NEMA 143TC frame motor.

Part No. Example
Basic Unit with ComTrac
K402AB0350 TD470K180-300



"K" Series – MGS® Adjustable Speed Drives Dimensional Data

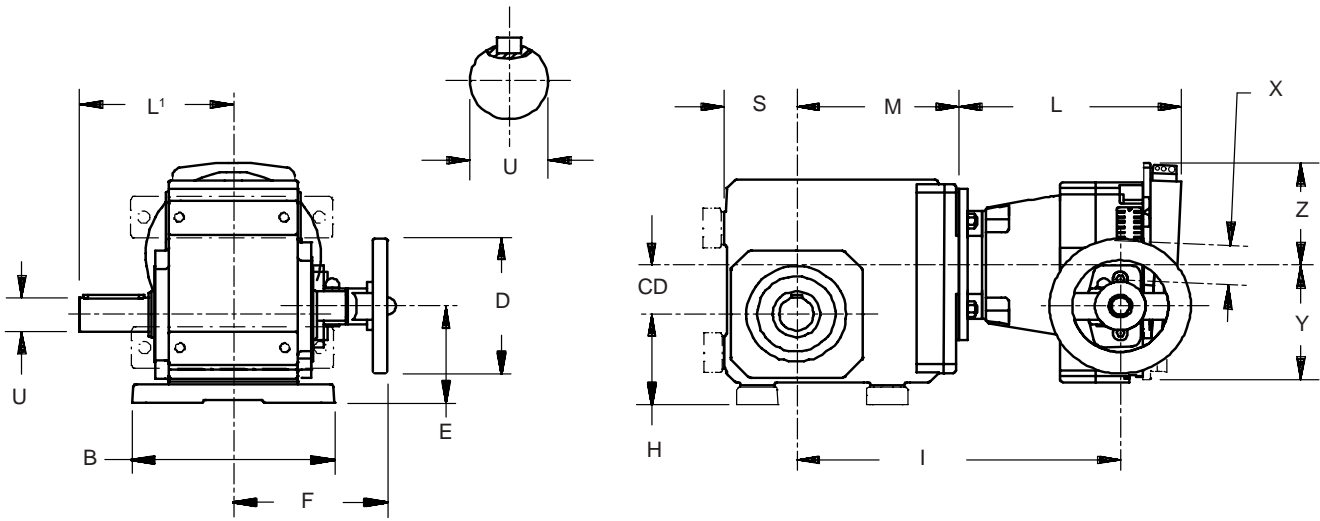

Drawing for Units
K102VN — K403VN

Table No. 1

"K" Series – Unit Dimensions (Inches)
"N" Housing Style

Base Module	B	H	L ¹	S	U
K102	5.51	2.36	4.53	2.36	1.000
K202	7.28	2.56	5.31	2.56	1.250
K302/K303	7.87	2.95	5.59	2.95	1.250
K402/K403	9.06	3.54	6.54	3.54	1.375
K513/K514	9.45	6.30	8.74	3.94	1.750
K613/K614	9.84	7.48	9.29	4.72	1.750
K713/K714	11.42	8.35	10.91	4.92	2.375
K813/K814	14.17	10.43	12.83	5.71	2.875
K913/K914	16.93	12.40	15.16	7.09	3.625
K1013/K1014	15.75 ⁽¹⁾	14.76	14.76	8.86	4.375

⁽¹⁾ Mounting feet are an integral part of the K10 housing.

Table No. 2

"K" Series – Unit Dimensions (Inches) – "N" Housing Style

ComTrac Part No.	NEMA C-Flange	D	F	L	X	Y	Z
TD270K050	56C	4.92	5.67	7.87	2.09	5.55	4.41
TD270K140	143/145TC	4.92	5.67	7.87	2.09	5.55	4.41
TD370K140	143/145TC	4.92	5.91	8.50	2.17	5.67	4.37
TD470K180	182/184TC	6.30	6.81	8.94	2.80	7.20	5.59
TD570K180	182/184TC	7.87	8.31	11.89	3.11	8.11	6.30
TD670K210	213/215TC	7.87	9.17	12.17	3.86	9.02	7.13
TD760K210	213/215TC	9.84	9.72	14.25	4.29	9.37	7.68

Table No. 3

"K" Series – "N" Housing Style – Approximate Weight (lbs.)

Part Number	K102	K202	K302	K303	K402	K403	K513	K514	K613	K614	K713	K714	K813	K814	K913	K914	K1013	K1014
TD270K050⁽²⁾	64	73	100	106	—	133	—	142	—	210	—	267	—	—	—	—	—	—
TD370K140	82	91	118	124	144	151	157	160	—	228	—	285	—	—	—	—	—	—
TD470K180	—	99	126	—	152	—	165	—	229	—	280	293	—	390	—	589	—	—
TD570K180	—	—	155	—	181	—	184	—	258	—	309	322	397	410	—	618	—	—
TD670K210	—	—	—	—	223	—	236	—	300	—	351	—	439	—	638	660	—	1123
TD760K210	—	—	—	—	—	—	—	—	364	—	415	—	503	—	702	—	1107	1187

⁽²⁾ Also available as TD270K140 for a NEMA 143TC frame motor.

See the MGS catalog for dimensions not shown.

"K" Series – MGS® Adjustable Speed Drives Dimensional Data

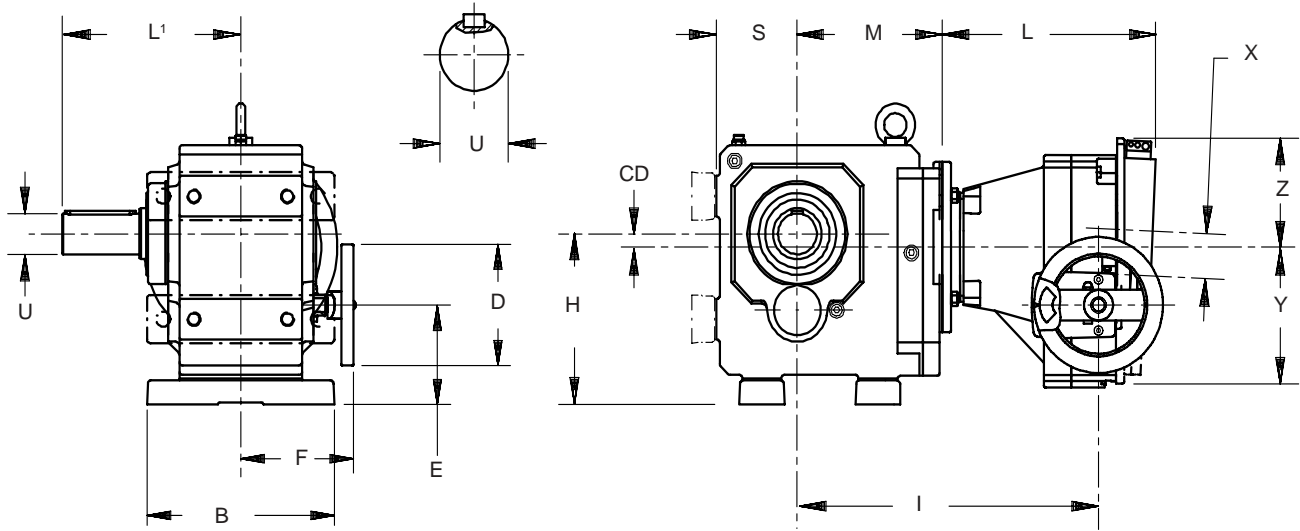

Drawing for Units
K513VN — K1014VN

Table No. 3 "K" Series – Unit Dimensions (Inches) – "N" Housing Style

Base Module	CD	TD270K050 ⁽³⁾			TD370K140			TD470K180			TD570K180			TD670K210			TD760K210		
		E	I	M	E	I	M	E	I	M	E	I	M	E	I	M	E	I	M
K102	1.42	2.20	7.87	5.04	1.73	8.50	5.04	—	—	—	—	—	—	—	—	—	—	—	—
K202	1.81	2.80	11.97	5.79	2.32	12.64	5.79	1.17	12.76	5.87	—	—	—	—	—	—	—	—	—
K203	1.81	—	—	—	—	—	—	—	—	—	—	—	—	—	—	—	—	—	—
K302	2.07	3.44	12.76	6.57	2.97	13.43	6.57	2.42	13.54	6.65	1.67	16.18	6.65	—	—	—	—	—	—
K303	.63	2.01	14.45	8.27	1.54	15.12	8.27	—	—	—	—	—	—	—	—	—	—	—	—
K402	2.36	—	—	—	3.86	14.21	7.36	3.31	14.33	7.44	2.56	16.97	7.44	2.36	17.28	7.56	—	—	—
K403	.91	2.87	15.24	9.06	2.40	15.91	9.06	—	—	—	—	—	—	—	—	—	—	—	—
K513	.59	—	—	—	3.66	13.62	6.77	3.11	13.74	6.85	2.36	16.38	6.85	2.17	16.69	6.97	—	—	—
K514	.59	4.13	14.65	8.46	3.66	15.31	8.46	—	—	—	—	—	—	—	—	—	—	—	—
K613	.71	—	—	—	—	—	—	4.17	14.49	7.60	3.43	17.13	7.60	3.23	17.44	7.72	3.23	19.88	8.27
K614	.71	5.20	15.39	9.21	4.72	16.06	9.21	—	—	—	—	—	—	—	—	—	—	—	—
K713	.79	—	—	—	—	—	—	4.96	15.59	8.70	4.21	18.23	8.70	4.02	18.54	8.82	4.02	20.94	9.33
K714	.79	5.98	16.54	10.35	5.51	17.20	10.35	4.96	18.03	11.14	4.21	20.67	11.14	—	—	—	—	—	—
K813	.94	—	—	—	—	—	—	—	—	—	6.14	19.25	9.72	5.94	19.53	9.80	5.94	21.93	10.31
K814	.94	—	—	—	—	—	—	6.89	19.02	12.13	6.14	21.65	12.13	—	—	—	—	—	—
K913	.98	—	—	—	—	—	—	—	—	—	—	—	—	7.87	21.30	11.57	7.87	23.70	12.09
K914	.98	—	—	—	—	—	—	8.82	20.79	13.90	8.07	23.43	13.90	7.87	24.09	14.37	—	—	—
K1013	1.10	—	—	—	—	—	—	—	—	—	—	—	—	—	—	—	10.11	14.25	15.43
K1014	1.10	—	—	—	—	—	—	—	—	—	—	—	—	10.11	12.16	17.72	10.11	14.25	18.70

⁽³⁾ Also available for a NEMA 143TC frame motor.

Part No. Example
Foot Mounting Unit with ComTrac
K402VN0350 TD470K180-300

MGS® Adjustable Speed Drives

Output Options

Output Bore or Shaft Diameters

Table No. 1 "C" Series – Output Shaft Diameter

Base Module	Inches		Metric ⁽¹⁾
	Standard	Stainless Steel	
C002	.750	.750	20
C102/C103	1.000	1.000	25
C202/C203	1.250	1.250	30
C302/C303	1.250	1.250	40
C402/C403	1.625	1.625	40
C512/C513	1.625	1.625	40
C612/C613	2.125	2.125	50
C712/C713	2.375	–	60
C812/C813	2.875	–	70
C912/C913	3.625	–	90

Table No. 2 "F" Series – Output Diameters Options

Base Module	Stainless Bushing Bores Sizes – inches													Hollow			Shaft	
	3/4	1	1 ³ / ₁₆	1 ¹ / ₄	1 ³ / ₈	1 ⁷ / ₁₆	1 ¹ / ₂	1 ⁵ / ₈	1 ¹¹ / ₁₆	1 ³ / ₄	1 ⁷ / ₈	1 ¹⁵ / ₁₆	2	Standard	Stainless	Metric ⁽¹⁾	Standard	Metric ⁽¹⁾
F102	x	—	—	—	—	—	—	—	—	—	—	—	—	.750	–	20	1.000	25
F202/F203	—	x	x	—	—	—	—	—	—	—	—	—	—	1.000	1.000	25	1.250	30
F302/F303	—	x	x	x	x	x	x	—	—	—	—	—	—	1.250	1.250	30	1.375	35
F402/F403	—	x	x	x	x	x	x	—	—	—	—	—	—	1.500	–	40	1.625	40
F602/F603	—	—	x	—	—	x	x	x	x	x	x	x	x	2.000	–	50	2.125	50

Table No. 3 "K" Series Output Shaft and Bore Diameters

Base Module	Hollow			Shaft		
	Standard	Stainless	Metric ⁽¹⁾	Standard	Stainless ⁽²⁾	Metric ⁽¹⁾
K102	1.000	1.000	25	1.000	1.000	25
K202/K203	1.187	1.250	30	1.250	1.250	30
K302/K303	1.375	1.250 & 1.375	30	1.250	1.250	30
K402/K403	1.500	—	40	1.375	1.375	40
K513/K514	2.000	—	50	1.750	1.750	45
K613/K614	2.000	—	50	1.750	1.750	50
K713/K714	2.375	—	60	2.375	2.375	60
K813/K814	2.750	—	70	2.875	2.875	70
K913/K914	3.250	—	90	3.625	—	90
K1013/K1014	4.000	—	100	4.375	—	110

Table No. 4 "K" Series – Stainless Steel Bushing Bores

Base Module	Stainless Steel Bushing Bores – inches															Metric 40	
	1	1 ³ / ₁₆	1 ¹ / ₄	1 ³ / ₈	1 ⁷ / ₁₆	1 ¹ / ₂	1 ⁵ / ₈	1 ¹¹ / ₁₆	1 ³ / ₄	1 ⁷ / ₈	1 ¹⁵ / ₁₆	2	2 ³ / ₁₆	2 ³ / ₈	2 ⁷ / ₁₆		2 ³ / ₄
K102	x	—	—	—	—	—	—	—	—	—	—	—	—	—	—	—	—
K202/K203	x	x	—	—	—	—	—	—	—	—	—	—	—	—	—	—	—
K302/K303	x	x	x	x	x	x	—	—	—	—	—	—	—	—	—	—	—
K402/K403	x	x	x	x	x	x	—	—	—	—	—	—	—	—	—	—	x
K513/K514	—	—	—	—	x	x	x	x	x	x	x	x	—	—	—	—	x
K613/K614	—	—	—	—	x	x	x	x	x	—	x	x	x	—	—	—	x
K713/K714	—	—	—	—	—	—	—	—	—	—	x	x	x	x	—	—	—
K813/K814	—	—	—	—	—	—	—	—	—	—	—	—	x	x	x	x	—

⁽¹⁾ Contact STOBBER Drives for availability.

⁽²⁾ "K" Series stainless steel shaft are single side ONLY.