



ComTrac® Adjustable Speed Drives Electric Remote Control

The STOBER Electric Remote Control (ERC) is a compact double reduction gearmotor which is pinion mounted to the motor slide track in place of the handwheel. A mechanical clutch within the unit indicates the end of vertical motor travel in both directions by making a clicking noise.

The ERC can be operated by push button or other type of control (not included) to adjust the drive's speed. In many applications it is advisable to use a limit switch with the ERC to prevent overspeed or underspeed conditions.

Features:

- Speed changes can be made when the unit is stationary or running.
- STOBER ERC can be quickly and easily added to existing ComTrac drives without special tools.
- All STOBER ERC units are designed for washdown/severe duty applications and are available from stock.
- Available voltages:
 - 115V, single phase, 60 Hz
 - 230/460V, three phase, 60 Hz

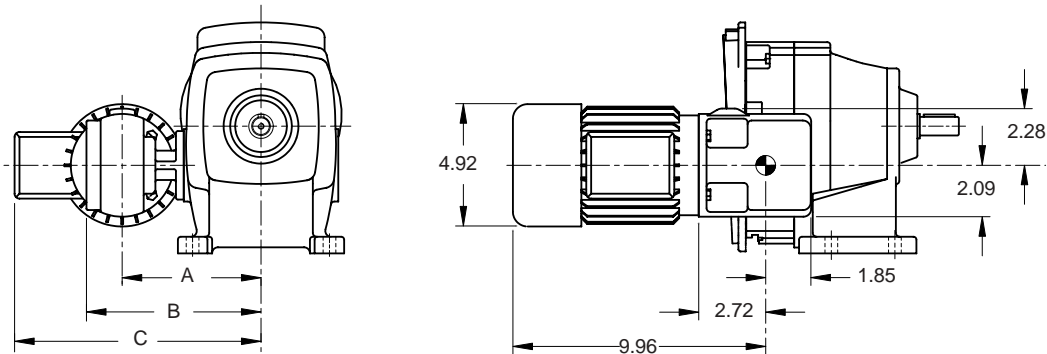

ERC for ComTrac sizes: TD27, TD37, and TD47.

Table No. 1 ERC – Dimensions (Inches)

ComTrac Size	Model Number		A	B	C
	Single Phase	Three Phase			
TD27	ERC27-1	ERC27-2	6.18	7.09	9.72
TD37	ERC37-1	ERC37-3	6.14	7.05	9.68
TD47	ERC47-1	ERC47-3	7.12	8.03	10.67
TD57	ERC57-1	ERC57-3	7.56	9.06	11.10
TD67	ERC67-1	ERC67-3	8.42	10.04	11.97
TD76	ERC76-1	ERC76-3	8.98	10.43	14.69

Motor dimensions may vary slightly from values shown.

● Reference point for handwheel center.

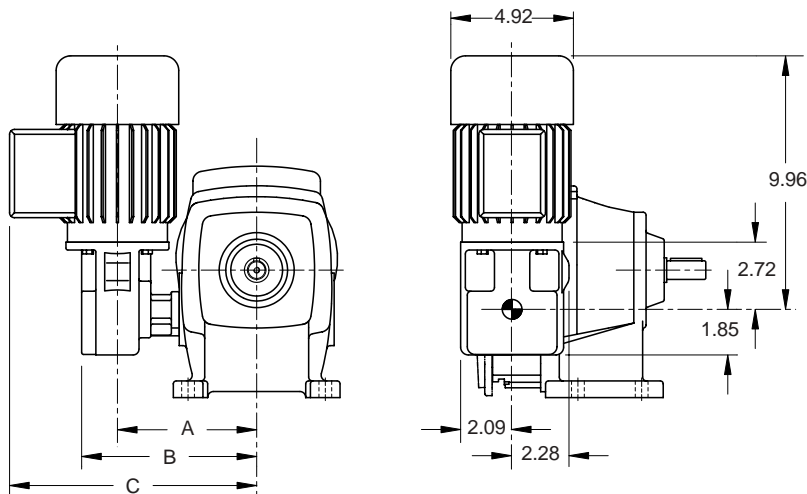

ERC for ComTrac sizes: TD57, TD67, and TD76.

ComTrac® Adjustable Speed Drives Limit Switch



Limit Switches are available for use with STOBBER Electric Remote Controls to turn current off to the motor should predetermined high or low speed limits be reached. Potentiometers (not included) can be installed with the limit switch to indicate speed settings.

Maximum rating is 230V, 60 Hz.

Table No. 2 LS – Dimensions (Inches)

ComTrac Size	Model Number	A	B	C	D
TD27	LS27	6.18	7.01	9.72	9.45
TD37	LS37	6.14	6.97	9.68	9.41
TD47	LS47	7.12	7.95	10.67	10.39
TD57	LS57	7.56	8.98	11.10	11.22
TD67	LS67	8.42	9.84	11.97	12.09
TD76	LS76	8.98	10.35	14.69	12.64

Motor dimensions may vary slightly from values shown.

⦿ Reference point for handwheel center.

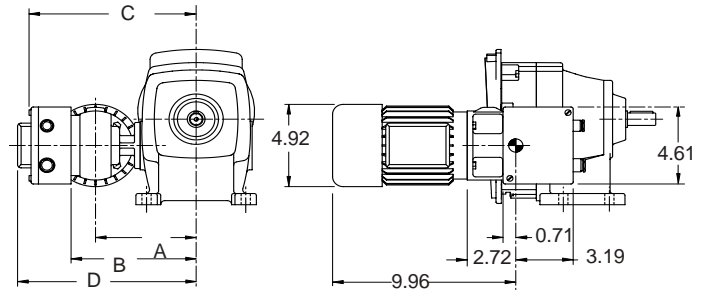

LS for ComTrac sizes: TD27, TD37, and TD47.

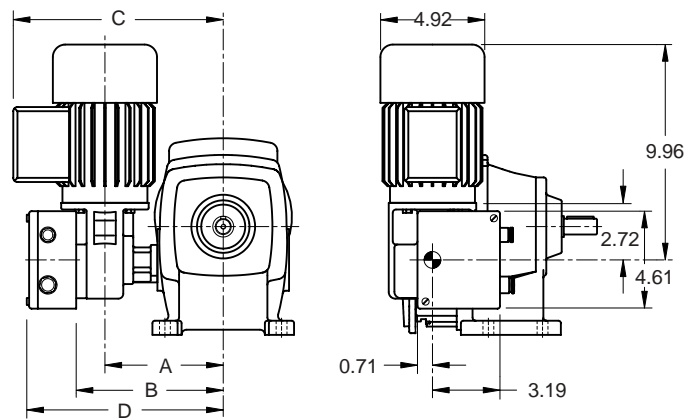

LS for ComTrac sizes: TD57, TD67, and TD76.

Motor Clearance

On some ComTrac units (TD270N, TD27-1, TD27-2) the motor can be lower than the base of the unit when adjusted to the slowest setting. The following formula will determine a value based on the length of the motor to be installed.

$$XX = .055 \times B \text{ (When "B" = motor length)}$$

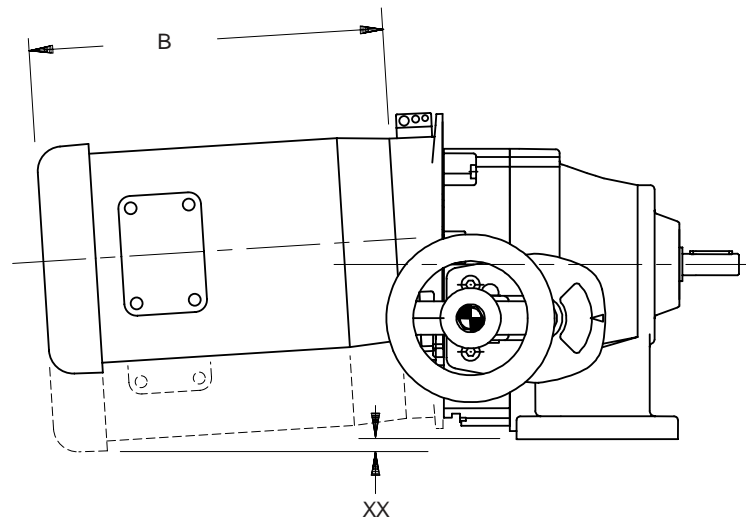

ComTrac® Adjustable Speed Drives

Selection and Performance Characteristics

Selection:

The ComTrac drives shown in the selection tables are rated for constant torque operation – where required horsepower varies directly in proportion to the speed of the driven machine.

All ratings shown are based upon standard NEMA C-face motor designs with 1750 RPM input speed. Contact STOBBER technical support for selection assistance for motor speeds other than 1750 RPM.

Basic selection procedure is as follows:

1. Establish the maximum horsepower required by the driven machine at maximum speed.

If only the driven equipment's maximum torque (T) requirement is known, use the following formula to convert the torque value to horsepower:

$$HP = \frac{T \times RPM}{63,025}$$

2. Select the drive which meets or exceeds the maximum HP rating of the driven machine at maximum speed.

Since the typical ComTrac application requires constant torque over the entire speed range, there will be an adequate service factor to protect the traction ring from damage.

Use the output speed ratings shown in the tables to select an output speed which meets or exceeds the requirement of the driven machine. Read across the table to determine if the drive's actual minimum and maximum speed, torque, and horsepower ratings meet the requirements of the driven equipment.

If the maximum output speed shown in the table is too low, go to the next higher speed. Should the torque or horsepower ratings shown be below the driven equipment's requirements, consult the next higher horsepower rating in the selection data.

Motor Performance

The ratings shown in the ComTrac selection tables are based on standard NEMA motors with the following specifications:

- 1750 RPM speed
- 60 Hz operation

Application Matched Options

Several options for ComTrac drives, such as remote controls, are included in this catalog. In addition, the following options are also available:

- 50 Hz operation for export
- Motor enclosures

For application and selection assistance for these options and others, contact your local STOBBER distributor.

Non-Standard Application Conditions

For constant horsepower applications, or any of the nonstandard application conditions shown below, contact STOBBER technical support.

Unusual Loading Conditions:

- Heavy shock load
- High inertia load
- Load reversals or overhauling loads
- More than ten starts per hour

Unusual Environmental Conditions:

- High altitudes – above 5000 feet
- Corrosive chemicals
- Excessively dusty or abrasive environments

- Ambient temperatures below 25° F or above 125° F

Nonstandard Motors:

- Motor frame sizes other than those shown in the tables

Nonstandard Mounting:

- Output shaft up or down (V5 or V6 mounting)

Not Recommended for Mounting:

- Explosive environment of any type

Performance Characteristics

Because of its mechanical operation, the ComTrac drive generally produces constant output torque. While the induction motor produces constant horsepower and constant speed, the two are combined in a manner that provides optimum utility and economy.

As the ComTrac Performance Chart shows, the drive has two operating regions.

1. Constant torque between the drive's absolute minimum speed and transition speed.
2. Constant horsepower between the transition speed and maximum speed.

When selecting a ComTrac drive, it is important to choose a unit which will not allow the cone and ring system to be overpowered by the motor. As shown in the ComTrac Performance Chart, ComTrac drives should always be selected so that the output torque required is well below the torque capability of the cone and the ring system.

Graph No. 1 ComTrac Performance Chart

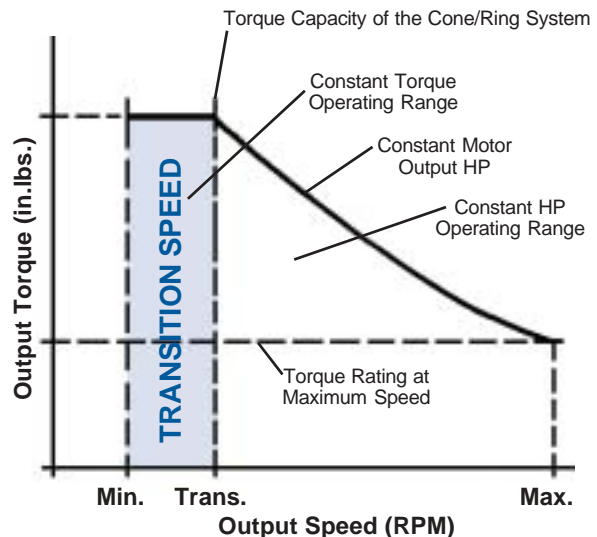

ComTrac® Adjustable Speed Drives Selection and Performance Characteristics

Overhung Loads

When a belt, chain, or gear is mounted on the output shaft of a ComTrac drive, the overhung load effect of the drive must not exceed the ratings shown in the Overhung Load Capacity table shown below.

To calculate the overhung load of the drive mounted on the output shaft, use the following formula:

$$OHL = \frac{126,000 \times HP \times K}{D \times RPM}$$

OHL = Overhung Load (lbs.)

HP = Horsepower

D = Pitch Diameter (inches) of sprocket, gear, sheave or pulley

K = 1.00 Chain Drive

1.25 Gear Drive or Gearbelt Pulley Drive

1.50 V-belt Drive

2.50 Flat Belt Drive

RPM = Maximum Speed (Revolutions per Minute)

No overhung loads are encountered when the ComTrac drive is direct coupled to a C-face speed reducer or when the ComTrac drive is connected by a coupling to the driven machine.

However, care should be taken to properly align the shafts to prevent pre-loading of the bearings.

Table No. 1

ComTrac Overhung Load Capacities (lbs) ⁽¹⁾

ComTrac Series ON, Non-Gear

Size	Output Shaft Speed (RPM)									
	2100	1800	1600	1400	1200	1000	800	600	450	300
TD27-0	152	158	166	174	182	191	202	219	238	270
TD37-0	242	248	258	270	284	300	316	338	371	411
TD47-0	302	312	324	338	353	371	393	425	461	517
TD57-0	382	393	405	416	430	450	483	517	562	629
TD67-0	494	500	510	528	550	584	630	675	730	810
TD76-0	650	660	680	700	735	770	820	880	950	1080

ComTrac Series 1, Single Reduction

Size	Output Shaft Speed (RPM)									
	1350	1050	800	590	440	310	210	130	70	30
TD27-1	150	160	172	190	210	235	255	290	350	440
TD37-1	275	295	315	340	370	405	450	520	610	760
TD47-1	350	370	400	430	460	515	580	650	770	955
TD57-1	495	525	560	610	670	730	810	900	1080	1350
TD67-1	495	525	560	610	670	730	810	900	1080	1350
TD76-1	730	775	820	880	950	1080	1200	1400	1600	2000

ComTrac Series 2, Double Reduction

Size	Output Shaft Speed (RPM)									
	280	215	150	110	75	50	32	26	16	8
TD27-2	335	360	395	430	465	505	555	610	675	830
TD37-2	560	585	625	675	730	800	880	960	1040	1190
TD47-2	720	775	830	890	950	1030	1120	1210	1320	1520
TD57-2	1800	1910	2025	2150	2300	2475	2650	2700	2700	2700

⁽¹⁾ Load applied evenly at the center of the shaft extension.

Graph No. 2 ComTrac Series 0F Output HP

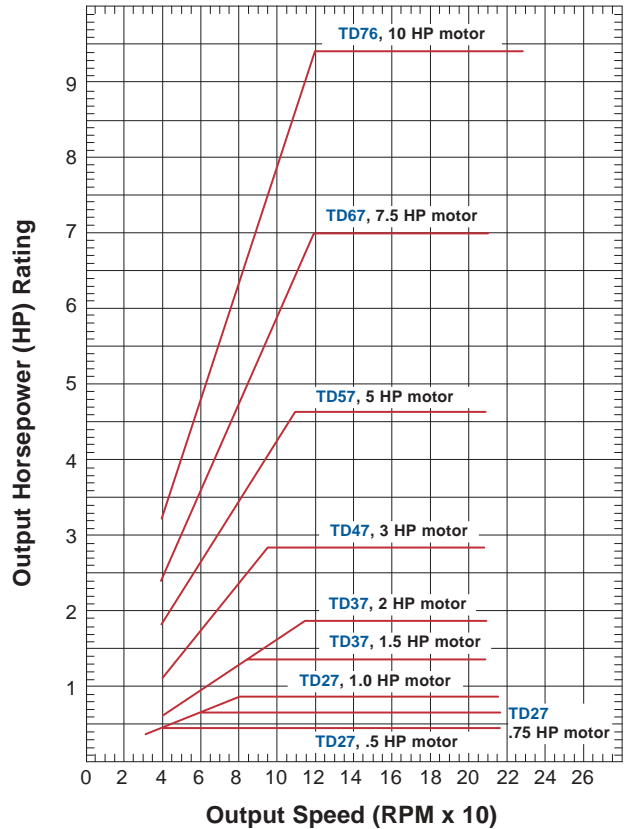

Table No. 2

ComTrac Series 0F Specifications

Motor HP	NEMA Frame	Output Torque in.lbs.	Model Number	C-Face Output Flange	Speed Range	Output Speed Range (RPM)	
						Max.	Min.
.50	56C	16	TD270F	56C	7:1	2180	311
.75	56C	24	TD270F	56C	7:1	2180	311
1.00	143TC	32	TD270F	56C	7:1	2180	311
1.50	145TC	48	TD370F	143/145TC	5:1	2100	420
2.00	145TC	64	TD370F	143/145TC	5:1	2100	420
3.00	182TC	99	TD470F	143/145TC	5:1	2100	420
5.00	184TC	168	TD570F	182/184TC	5:1	2100	420
7.50	213TC	250	TD670F	182/184TC	5:1	2100	420
10.00	215TC	340	TD760F	213/215TC	5:1	2100	420

Minimum output torque rating based on 1750 RPM maximum input speed.

ComTrac® Adjustable Speed Drives Installation Instructions

In order to obtain long life and trouble-free operation from your ComTrac® drive, it is essential that proper installation and operating procedures be followed.

The torque required by the application must not exceed the reducer torque capacity shown on the nameplate. For safety purposes a safety coupling should be installed between the reducer and the driven load. Otherwise, overload may cause damage to the interior parts of the reducer which may result in breaking the reducer housing. As a result, persons could be injured by flying parts or splashing hot gear oil.

This catalog includes basic directions for mounting and start-up of the ComTrac® drive, as well as lubrication information. Failure to follow these instructions will void the drive's warranty.

If you have questions about the installation, operation or maintenance of your ComTrac® drive, please contact your local STOBBER distributor for assistance.

WARNING:

Safety is the most important consideration when operating any type of drive. Through proper application, safe handling methods, and wearing appropriate clothing, you can prevent accidents and injury to yourself and fellow workers.

The shafts of ComTrac® drives rotate at very high speeds and can cut off or severely injure hands, fingers, and arms. Use appropriate guards for shafts and other rotating parts at all times. Follow all directions in the service instruction manual. Obey all federal, state and local safety regulations when operating the drive.



- Always be sure electrical power is off while making electrical connections and during installation and maintenance of the unit.
- Keep clothing, hands, and tools away from ventilation openings on motors and from all rotating parts during operation.
- Lift drive with a double rope sling or other proper lifting equipment of adequate strength. Make sure load is secured and balanced to prevent shifting when unit is being moved. Lifting heavy drives by hand may be dangerous and should be avoided.
- The intended use of lifting lugs is to handle the weight of the unit only. Never use a lifting lug to lift attached assemblies.
- Never operate drive at speeds higher than those shown on the nameplate, or personal injury may result. Contact STOBBER Drives Inc., if there is any change of operating conditions from those for which the unit was originally sold (as stamped on the nameplate). Failure to comply could result in personal injury and or machinery damage.
- Always follow good safety practices at all times.

Each drive is tested before delivery. Before installation, however, it is advisable to examine the unit for possible damage which might have occurred during transit. If damage is discovered, it should be immediately reported to the transport agent.

If installation is delayed after receipt of the MGS speed reducer, the drive should be stored in a clean, dry place until put into service. Long term storage requires special procedures. If not kept in a heated, dry area, consult STOBBER Drives, Inc. for storage instructions.

NOTE: If it is necessary to clean drive shafts, take care to protect the oil seals.

IMPORTANT: Do not use any device to hammer the unit onto the output shaft during installation since the bearing races could be damaged.

Unit Installation

ComTrac Series 1 and 2

Geared drives have integral mounting feet and are designed to be mounted on rigid foundations. All housing feet must rest firmly on supports before being bolted down. Use shims to level the drive and proper size foundation bolts to secure the drive to the foundation. Use flat washers between the heads of the bolts and the housing feet.

Geared drives are shipped from the factory filled with oil for mounting in the horizontal (B3) position. If wall or ceiling mounting is required, see lubrication instructions.

If vertical mounting (output shaft up or down) is required, consult STOBBER Drives Inc. at the time of purchase.



ComTrac Series 0N

Non-geared units with integral mounting feet require the same attention to mounting as outlined for geared drives, Series 1 and 2. These drives can be horizontal, wall, ceiling, or vertically mounted without concern for lubrication or other modification.

ComTrac Series 0F

Non-geared units with C-face input and output are designed to attach to any speed reducer with a NEMA C-face input. Care must be taken to follow the speed reducer manufacturer's recommended mounting instructions.



NOTE: ComTrac Series 0F drives do not have mounting feet. The drive and motor assembly is mounted on the speed reducer which must support the reducer, ComTrac, and the motor. If there is concern for the ability of the reducer mounting feet to support the entire assembly, a larger speed reducer may be required.

The output shaft of the ComTrac drive is shipped from the factory with a protective coating. Remove this coating with a suitable nonflammable solvent. Precaution must be taken not to allow the solvent to contact the output shaft oil seal, since damage to the seal may occur.

ComTrac® Adjustable Speed Drives Installation Instructions

Motor Installation



Step 1

Remove the access cover.



Step 2

Lubricate and insert keyed motor shaft into the slotted bore of the drive cone shaft.

NOTE: For ease of installation, secure the key to the motor shaft. (Staking near the end of the keyway or a temporary adhesive works well.)



Step 3

Tighten the four motor flange bolts.

IMPORTANT: Jog the motor several revolutions before tightening the motor clamp to assure proper position of the drive cone on the motor shaft. See Page 5 for an illustration.



Step 4

Through the access hole, tighten the hex socket screw on the motor clamp hub to the tightening torque shown in the table below. The correct size hex wrench is provided. **DO NOT OVERTIGHTEN.**

SHOWN WITHOUT MOTOR FOR DEMONSTRATION PURPOSE.



Table No. 1

Clamp Ring Setscrew Tightening Torque

ComTrac Size	in. lbs.	ComTrac Size	in. lbs.
TD27	88.5	TD57	434
TD37	88.5	TD67	434
TD47	221	TD76	434



Step 5

Reattach access cover.

When couplings, gears, sprockets or pulleys are mounted on the output shaft, be sure to mount them as close as possible to the housing to minimize the effects of overhung loads on shafts and bearings.

CAUTION: Do not drive couplings, sprockets, gears or pulleys onto the output shaft with hard hammer blows, since damage to internal gears or bearings will result. All output shafts have a metric centering thread for attachment of transmission devices. They can be pulled on gently with a bolt and plate.

ComTrac® Adjustable Speed Drives

Installation Instructions

Handwheel Position

ComTrac drives are furnished with the speed control handwheel on the left, as viewed from the output shaft end of the drive. If it is necessary that the handwheel be moved to the opposite side, this can be accomplished very easily with the hex wrenches provided with each drive.

Procedure



Step 1

Remove the three (3) plastic plugs in the housing on the side opposite the handwheel.



Step 2

Remove the handwheel and indicator assembly by removing the two (2) socket-head capscrews which secure the handwheel indicator assembly to the housing.



Step 3

Turn the yellow numbered position indicator wheel around by removing the slotted screw. (Be sure to remove the tape covering to expose position numbers on the other side of the wheel.)



Step 4

Replace the slotted screw.

Step 5

Place pinion, handwheel and indicator on desired side of the drive's housing (from where the three plastic plugs were removed), and secure with the two socket-head capscrews removed previously.



Step 6

Relocate the plastic plugs to the holes where the handwheel was originally mounted.

Lubricate the motor slide and rack (both sides) with **one** (1) stroke with a grease gun through the fittings provided in the housing. **IMPORTANT: Do not over lubricate the motor slide.** Under normal conditions, maintenance of the motor slide and rack should only be required one time per year.

Electric Remote Control (ERC) Installation

The Electric Remote Control consists of a small gearmotor mounted on the ComTrac drive in place of the manual handwheel control.

Procedure

Attaching the ERC is accomplished by simply removing the two (2) socket-head capscrews that secure the handwheel and indicator assembly to the drive's housing.

Replace the handwheel/indicator assembly with the ERC and secure it to the housing with the same two screws.

Lubricate the motor slide and rack (both sides) with one (1) stroke with a grease gun through fittings in the housing.

The ERC is operated by pushbutton or other form of contact (furnished by customer). A mechanical clutch is contained within the gearmotor which indicates the end position of travel, in either direction, by making a clicking noise. Also, the ERC can be operated while the drive is stationary.

Power required for the ERC is 230 volt, 3 phase, 60 hertz, or 115 volt, single phase, 60 hertz.

The wiring diagram for the ERC is inside the motor's conduit box.

The ERC motor and drive should be protected from excessive dust, flying chips, and oil splashes.

ComTrac® Adjustable Speed Drives Maintenance and Lubrication Instructions

Maintenance and Lubrication

WARNING: Before beginning any work on the ComTrac drive system, disconnect the power source (lock-out the motor starter, and unload breakers, backstops, etc.). Failure to do so may cause serious personal injury and/or machinery damage.

Non-geared drives – Series 0N and 0F

These units require lubricant only in the cam and bearing chamber and are shipped with the lubricant in them. There is a sufficient quantity of lubricant to allow mounting the non-geared ComTrac Drive in any position.

Table No. 1
Series "0" – Bearing and Cam Chamber Oil Quantity

ComTrac Size	fluid ozs.	ComTrac Size	fluid ozs.
TD27-0	1.5	TD57-0	4.4
TD37-0	1.7	TD67-0	5.4
TD47-0	1.9	TD76-0	6.1

For normal indoor installations the handwheel or ERC control pinion and motor slide rack should be lubricated through the grease fitting every six months using NLGI No. 2 grease. One stroke of a grease gun is sufficient. When the drive is operating under wet conditions, increase the frequency of lubrication to once a month.

Under normal operating conditions the synthetic oil in the cam and bearing chamber does not need to be replaced. If for any reason some quantity of lubricant is lost, remove the rest of the lubricant from the cam and bearing chamber and replace it with the type and quantity of oil listed in the lubrication table shown.

Table No. 2 Bearing and Cam Oil Manufacturers

Lubricant Manufacturer	AGMA Lubricant (No. 5EP)
Darmex	9140
Exxon	Spartan 220
Mobil *	Mobilgear 630
Gulf	HD220
Keystone	KSL-366
Lubriplate	APG90

* Mobile SHC626 is used for the initial fill. If refill is necessary, any of the above products may be used.

For installations in the food, dairy, beverage and baking industries, where special lubricants are required, a suitable grease of the user's preference should be used.

When a ComTrac Drive with C-face output (Series 0F) is attached to a speed reducer, follow the manufacturer's lubrication instructions for the reducer mounting before start-up.

ComTrac Drives – Series 1 and 2

These drives are shipped with the correct amount of No. 4 EP oil for horizontal mounting. If the drive is to be mounted in another position (wall or ceiling) it will be necessary to drain the oil and refill the drive with the correct amount of lubricant before start-up.

Table No. 3
Series "1 and 2" – Oil Quantity (ozs.)

ComTrac Series 1	Mounting Position			ComTrac Series 2	Mounting Position		
	B3	B6/B7	B8		B3	B6/B7	B8
TD27-1	14	10	15	TD27-2	14	17	15
TD37-1	14	15	19	TD37-2	32	32	32
TD47-1	19	22	32	TD47-2	39	41	41
TD57-1	24	30	41	TD57-2	61	81	81
TD67-1	27	37	47	–	–	–	–
TD76-1	61	81	112	–	–	–	–

Mounting Positions

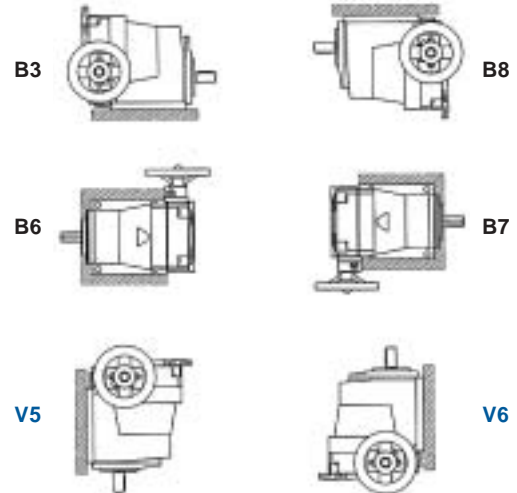

If vertical mounting (output shaft down-V5 or shaft up-V6) is required, contact STOBBER Drives, Inc.

Table No. 4
Lubricant Manufacturers

Lubricant Manufacturer	Ambient Temperature	
	+15°F to +60°F AGMA (2EP)	+50°F to +125°F AGMA (4EP)
BP	BP ENERGOL GR-XP-68	–
Chevron	–	AW Mach. Oil 150
Exxon	Spartan EP-68	Spartan EP-150
Mobil	Mobilgear 626	Mobilgear 629
Shell	Omala 68	Omala 250
Texaco	Meropa 68	Meropa 150