

Disco variable speed drives

Dimensions with helical-bevel gearboxes

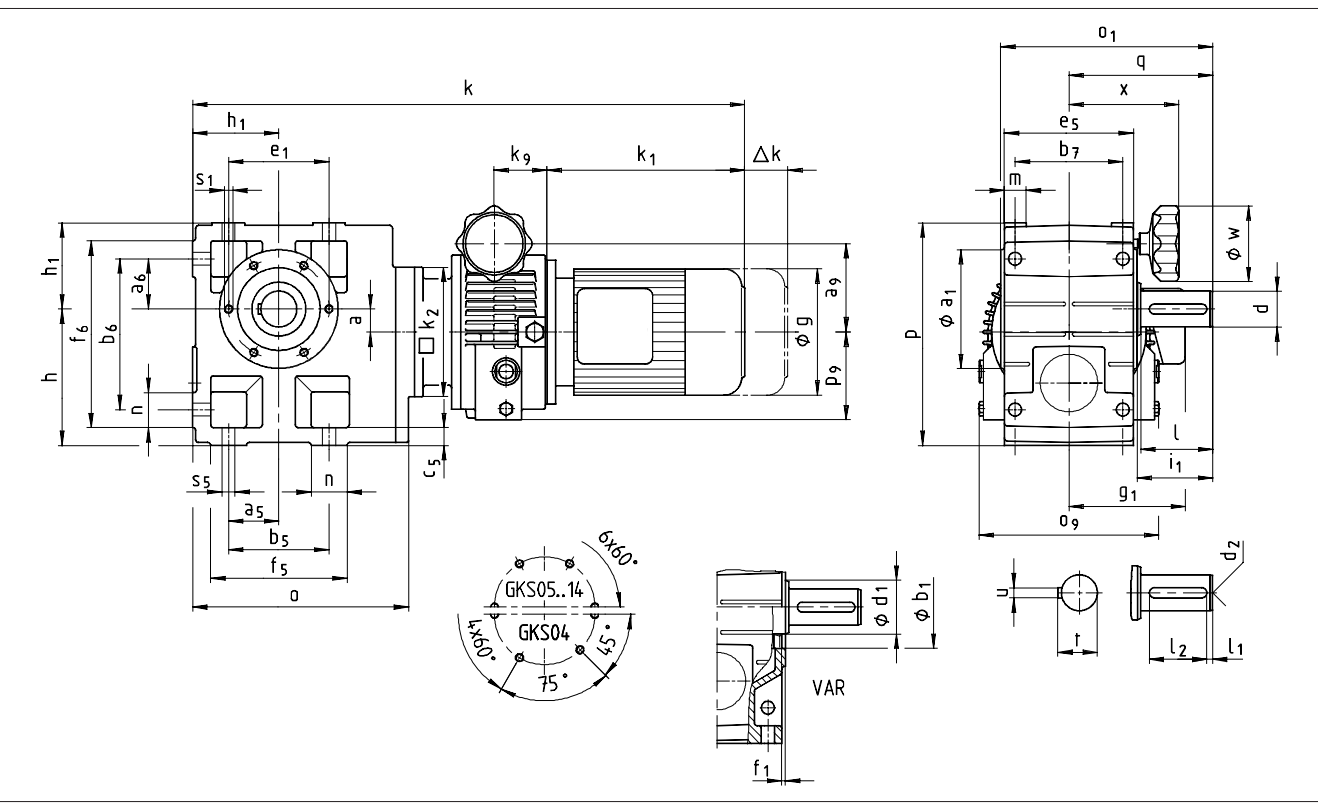
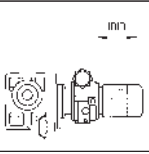

Disco variable speed drives		Drive size																					
GKS □□ - 3 D V □ R		071-1□ 02	071-3□ 03	080-3□ 04	090-3□ 05	100-32 06	112-22 07	132-12 18	132-22 08														
Motor	g	143	143	160	180	206	222	274	274														
	g₁	Without options	128	128	137	147	140	174	196	196													
		Brake motor	131	131	142	154	151	174	212	212													
	k₁	237	237	267	350	316	379	450	450														
	Δk Brake	54	54	36	48	111	80	63	63														
DISCO	a₉	83	86	103	123	149		190															
	k₂	145	145	180	180	265		300															
	k₉	42	50	58	74	82		104															
	o₉	150	175	215	253	305		379															
	p₉	65	83	98	122	145		176															
	w	70	70	105	105	105		160															
	x	105	105	152	152	152		195 1)															
Gearbox size	Gearbox							Total length															
	o	o ₁ *	p*	h**	h ₁	a	q	k															
GKS 04	203	163	171	100	71	20	1075	576	589	649													
GKS 05	232	197	205	125	80	23	130	596	609	669	781												
GKS 06	291	236	250	150	100	28	160	652	665	725	837												
GKS 07	354	296	310	190	120	34	200	708	721	781	893	890	953	1060	1060								
GKS 09	429	356	386	236	150	41	240		852	964	961	1024	1131	1131									
GKS 11	527	445	485	300	185	54	305			1055	1052	1115	1222	1222									
GKS 14	636	544	605	375	230	67	375				1151	1214	1321	1321									

Gearbox size	Solid shaft								Pitch circle						Foot											
	d	l	d ₁	l ₁	l ₂	d ₂	u	t	a ₁	b ₁ H7	e ₁	f ₁	i ₁	s ₁	a ₅	a ₆	b ₅	b ₆	b ₇	c ₅	e ₅	f ₅	f ₆	n	m	s ₅
GKS 04	25	50	45	4	40	M10	8	28	105	75	90	3	52.5	M6x12	45	45	110	119	85	14	105	132	141	22	21	9
GKS 05	30	60	50	6	45	M10	8	33	118	80	100	4	64	M8x15	47.5	47.5	115	140	105	17	127	144	169	29	21	11
GKS 06	40	80	65	7	63	M16	12	43	140	100	120	4	85	M10x16	60	60	155	170	120	20	145	191	206	36	23	14
GKS 07	50	100	75	8	80	M16	14	53.5	165	115	140	5	105	M12x18	70	70	190	210	150	25	180	235	255	45	28	18
GKS 09	60	120	95	8	100	M20	18	64	205	145	175	6	125	M16x24	90	90	240	266	185	30	222	300	326	60	37	22
GKS 11	80	160	105	15	125	M20	22	85	240	140	205	6	166	M20x32	105	105	290	325	225	40	270	363	398	73	43	26
GKS 14	100	200	135	18	160	M24	28	106	290	170	250	6	207	M24x35	135	135	360	415	275	50	328	442	497	82	52	33

Dimensions in [mm] d ≤ 50 mm: k6 * Observe dimension k₂ 1) Plus 80 mm for handle
 d > 50 mm: m6 ** Observe dimension p₉

Disco variable speed drives

Dimensions with helical-bevel gearboxes

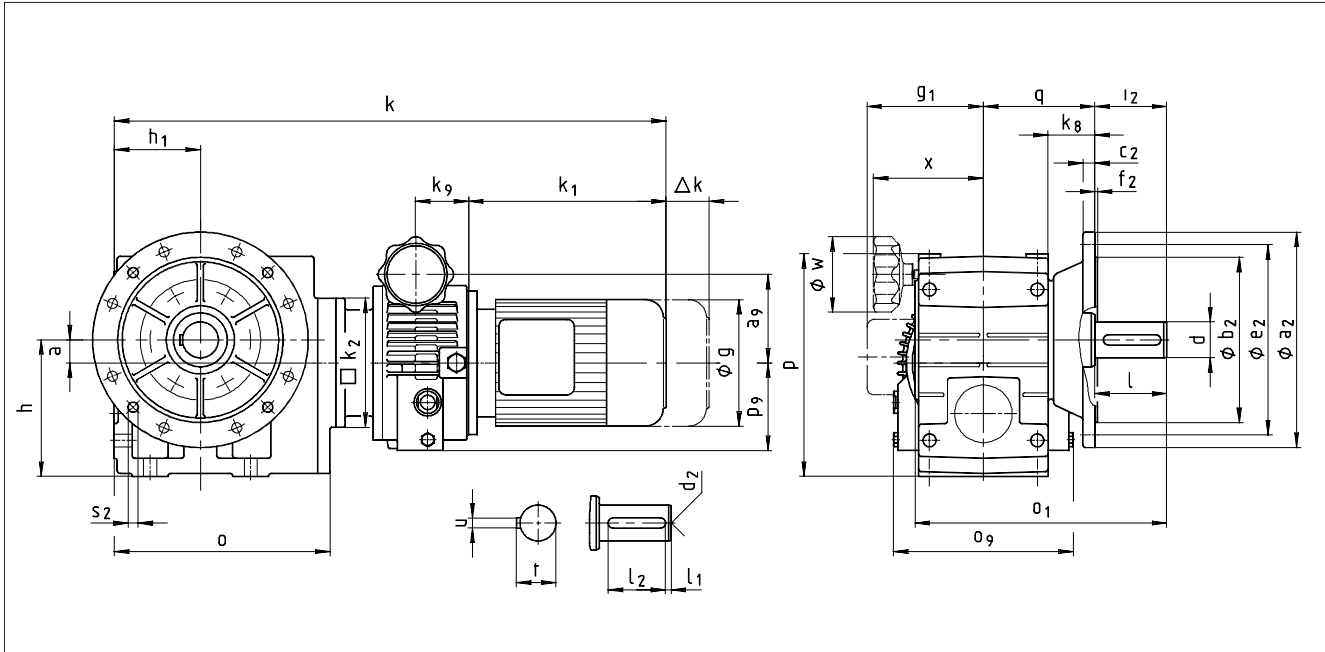
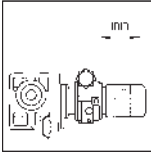

Disco variable speed drives GKS □□ - 3 D VAK		Drive size														
		071-1□ 02	071-3□ 03	080-3□ 04	090-3□ 05	100-32 06	112-22 07	132-12 18	132-22 08							
Motor	g	143	143	160	180	206	222	274	274							
	g₁ Without options	128	128	137	147	140	174	196	196							
	Brake motor	131	131	142	154	151	174	212	212							
	k₁	237	237	267	350	316	379	450	450							
	Δk Brake	54	54	36	48	111	80	63	63							
DISCO	a₉	83	86	103	123	149		190								
	k₂	145	145	180	180	265		300								
	k₉	42	50	58	74	82		104								
	o₉	150	175	215	253	305		379								
	p₉	65	83	98	122	145		176								
	w	70	70	105	105	105		160								
	x	105	105	152	152	152	195 1)									
Gearbox size	Gearbox							Total length								
	o	o ₁ *	p*	h**	h ₁	a	k ₈	q	k							
GKS 04	203	196	171	100	71	20	38	90.5	576	589	649					
GKS 05	232	230	205	125	80	23	40	103	596	609	669	781				
GKS 06	291	277	250	150	100	28	49	121	652	665	725	837				
GKS 07	354	351	310	190	120	34	65	155	708	721	781	893	890	953	1060	1060
GKS 09	429	416	386	236	150	41	69	180	852		964	961	1024	1131	1131	
GKS 11	527	505	485	300	185	54	70	205	1055			1052	1115	1222	1222	
GKS 14	636	604	605	375	230	67	71	235				1151	1214	1321	1321	

Gearbox size	Solid shaft								Output flange						
	d	l	l ₁	l ₂	d ₂	u	t	a ₂	b ₂ j7	c ₂	e ₂	f ₂	i ₂	s ₂	
GKS 04	25	50	4	40	M10	8	28	160	110	10	130	3.5	50	4 x 9	
GKS 05	30	60	6	45	M10	8	33	200	130	12	165	3.5	60	4 x 11	
GKS 06	40	80	7	63	M16	12	43	250	180	14.5	215	4	80	4 x 14	
GKS 07	50	100	8	80	M16	14	53.5	250 300	180 230	14.5 16.5	215 265	4	100	4 x 14	
GKS 09	60	120	8	100	M20	18	64	350	250	18	300	4	120	4 x 17.5	
GKS 11	80	160	15	125	M20	22	85	400 450	300 350	20 22	350 400	5	160	4 x 17.5 8 x 17.5	
GKS 14	100	200	18	160	M24	28	106	450	350	22	400	5	200	8 x 17.5	

Dimensions in [mm] d ≤ 50 mm: k6 * Observe dimension k₂ 1) Plus 80 mm for handle
d > 50 mm: m6 ** Observe dimension p₉

Disco variable speed drives

Additional dimensions GKS

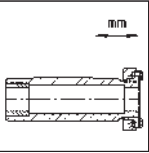

Torque plate at housing foot

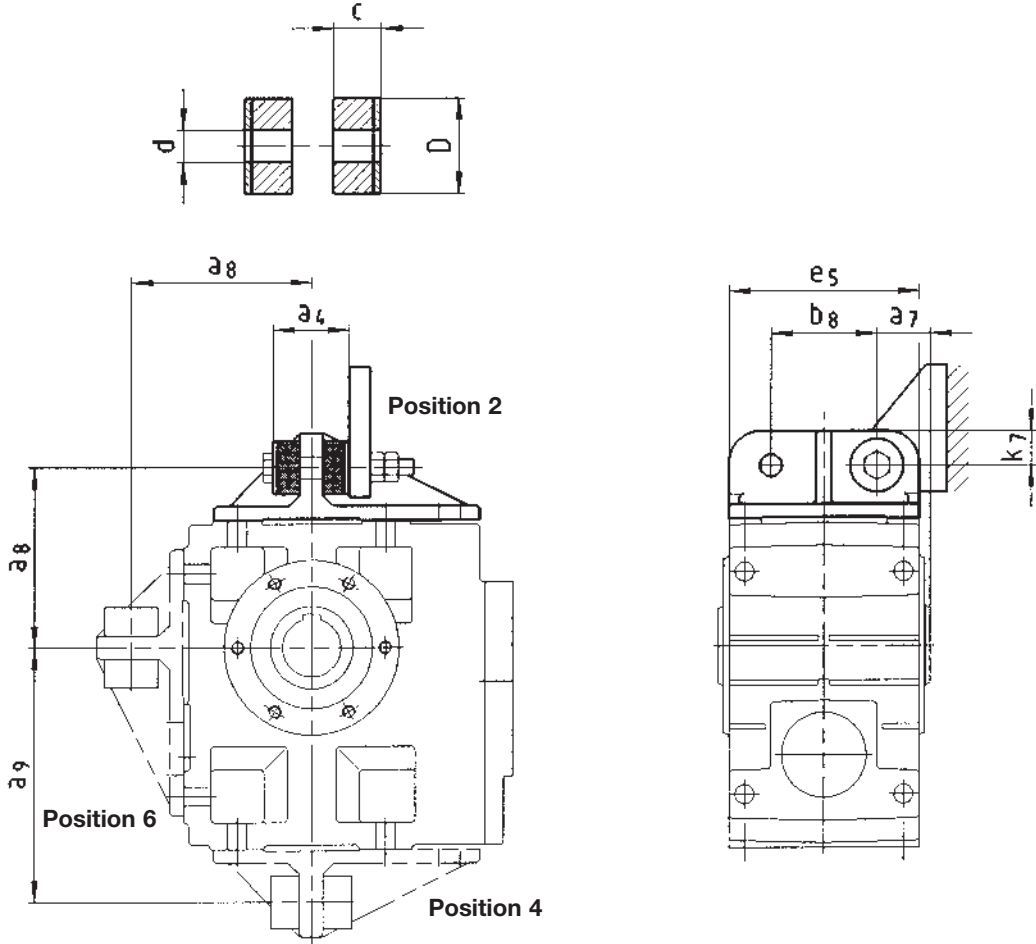

Gearbox size	a_4	a_7	a_8	a_9	b_8	c	d	D	e_5	k_7
GKS 04	41	27.5	106	135	60	14.5	11	30	100	20
GKS 05	45	35	115	160	70	15	13	40	127	25
GKS 06	72	40	145	195	80	27	17	50	145	30
GKS 07	78	50	170	240	100	28	21	60	180	35
GKS 09	86	60	214	300	120	29	26	72	222	46
GKS 11	94	72.5	260	375	145	30	33	92	270	55
GKS 14	100	85	320	465	180	30	39	110	328	70

Dimensions in [mm]

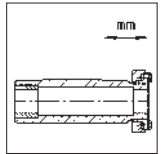

Torque plate at pitch circle in position 3

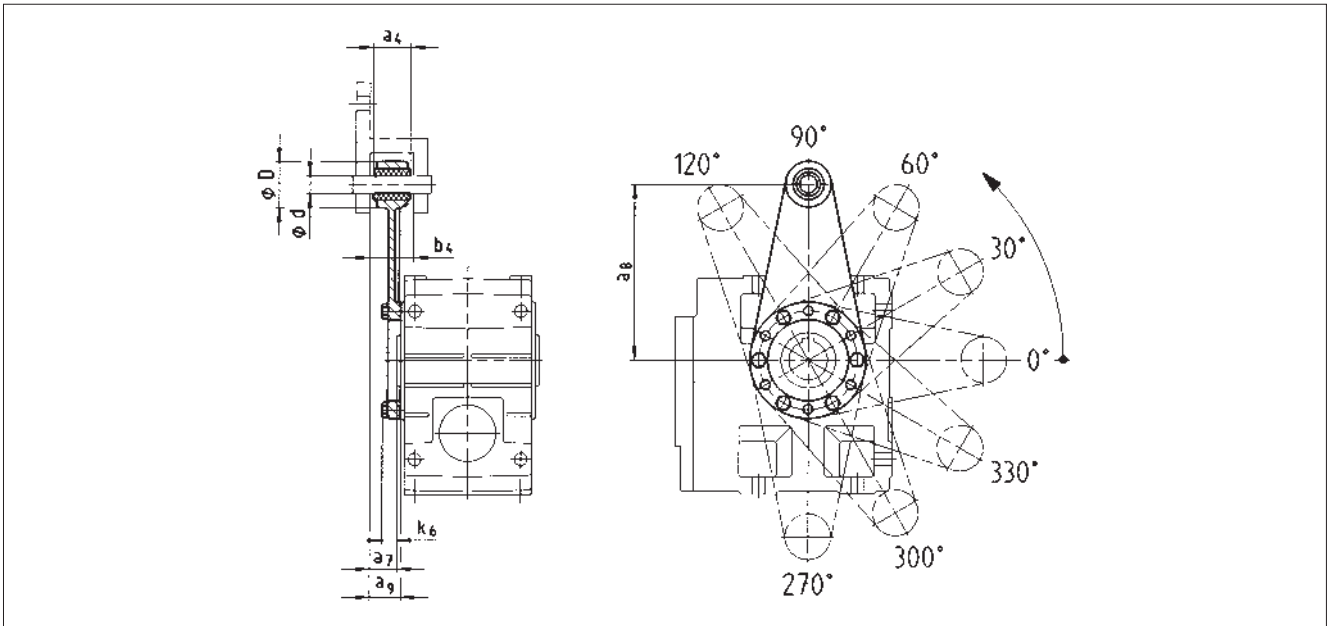

4

Torque plate at pitch circle in position 5

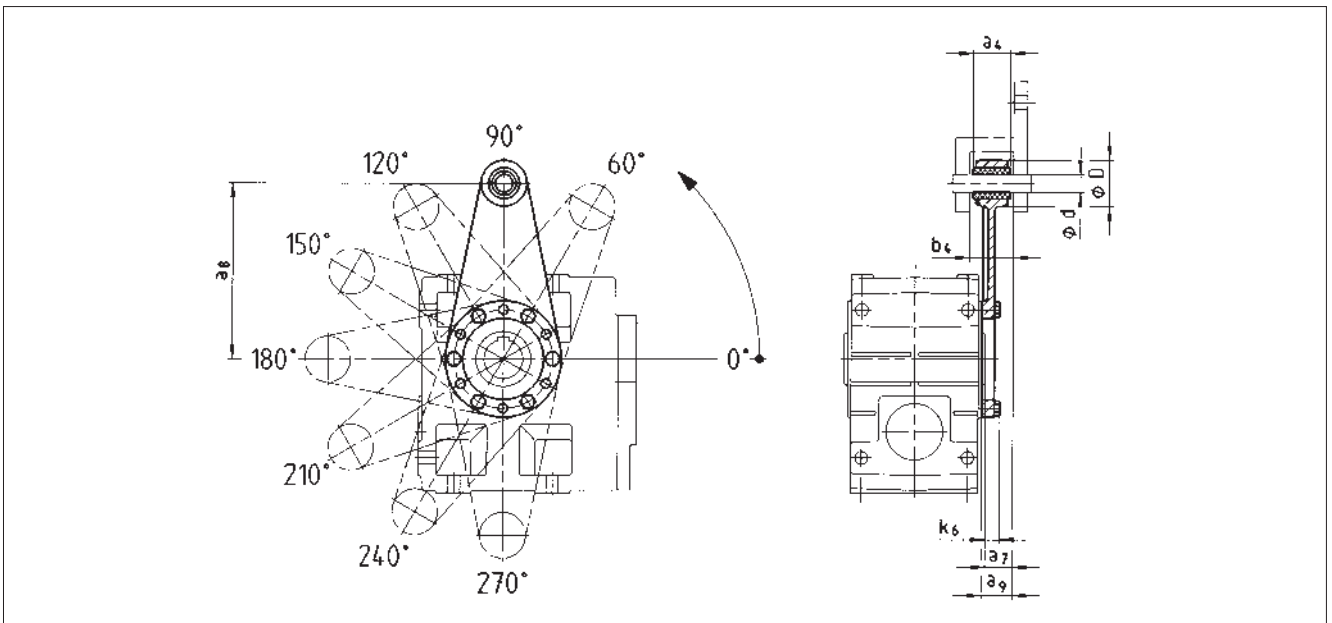

Gearbox size	Mounting space		Torque plate					
	a ₇	b ₄	a ₄	a ₈	a ₉	d	D	k ₆
GKS 04	24	34.5	30	130	26.5	12	35	16
GKS 05	23.5	38.5	34	160	27.5	16	45	15
GKS 06	28	44.5	40	200	33	20	50	18
GKS 07	32.5	50.5	46	250	37.5	25	65	21

Dimensions in [mm]

Disco variable speed drives

Additional dimensions GKS □ □

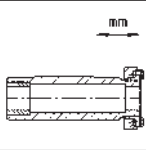

Hollow shaft with shrink disc

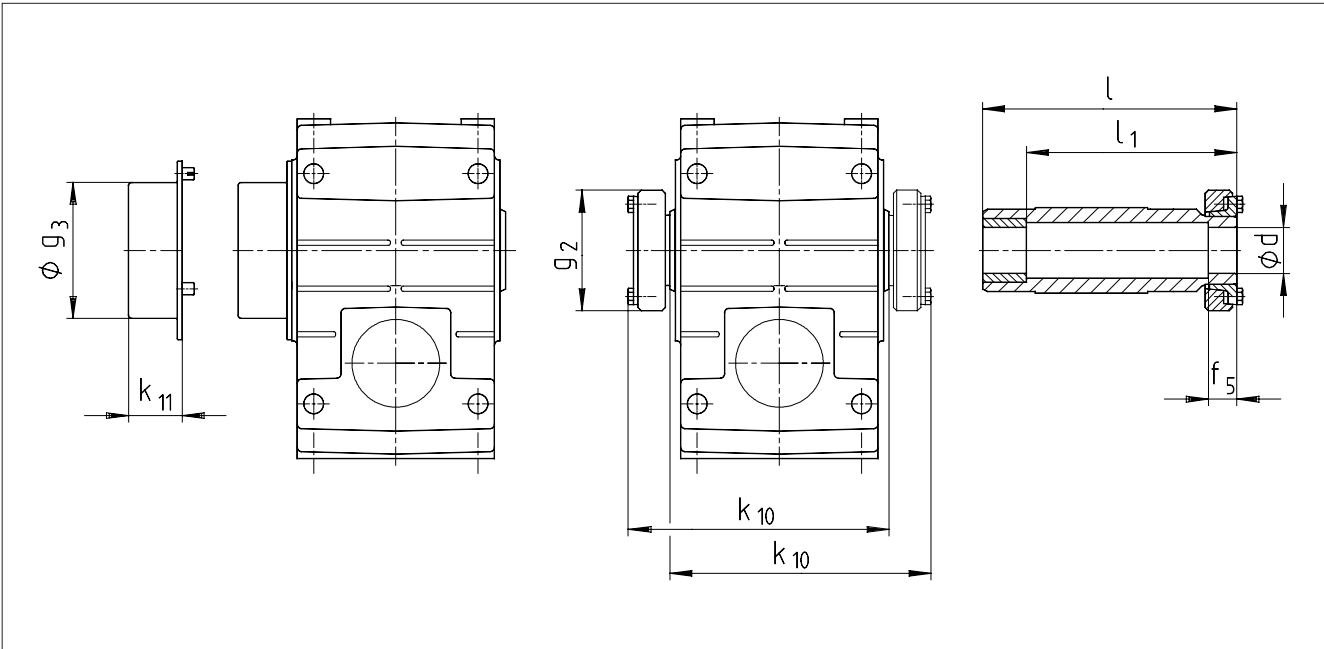

Gearbox size	Machine shaft*		Hollow shaft			Gearbox		Cover	
	d	Fit	l	l ₁	f ₅	g ₂	k ₁₀	g ₃	k ₁₁
GKS 04	25 30	h6	142	122	26	72	146	79	41
GKS 05	35	h6	168	148	28	80	171	90	43
GKS 06	40	h6	194	164	30	90	197	100	49
GKS 07	50	h6	232	192	26	110	234	124	49
GKS 09	65	h6	278	228	30	141	281	159	52
GKS 11	80	h6	338	238	42	170	344	191	65
GKS 14	100	h6	407	307	55	215	415	253	78

* Ensure sufficient strength of shaft material for shrink disc designs. When using customary steel (e.g. C45, 42CrMo4), the torques indicated in the selection tables can be transferred without any reservation. When using materials of a lower strength, please contact Lenze.

The average peak-to-valley height R_z should not exceed 15 μm. (Turning operation is sufficient).

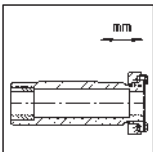

Disco variable speed drives

Additional dimensions GKS □ □

Gearboxes with 2nd output shaft end

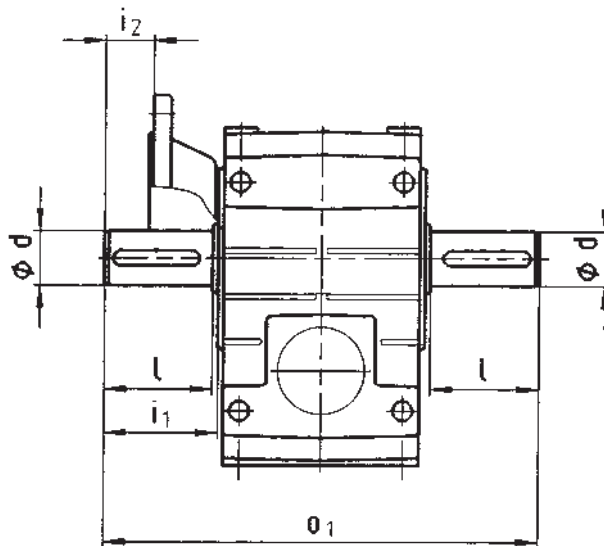

Gearbox size	d	l	i_1	i_2	o_1
GKS 04	25	50	52.5	17	215
GKS 05	30	60	64	27	260
GKS 06	40	80	85	39	320
GKS 07	50	100	105	45	400
GKS 09	60	120	125	60	480
GKS 11	80	160	166	100	610
GKS 14	100	200	207	140	750

Dimensions in [mm]