

Ansicht / View V:

Vierkant-Flansch / Square flange

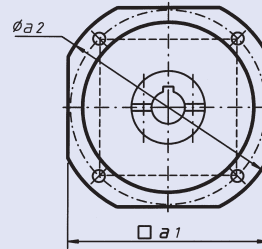

Bohrbild bei 4 Anschraublöchern
4-hole arrangement

Runder Flansch / Round flange

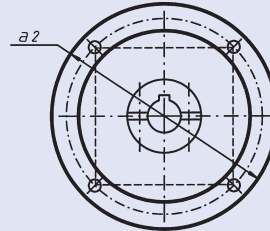

Bohrbild bei 4 Anschraublöchern
4-hole arrangement

Runder Flansch / Round flange

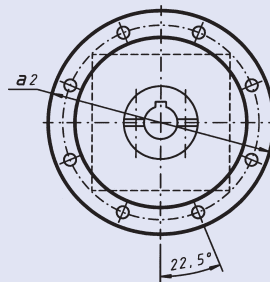

Bohrbild bei 8 Anschraublöchern
8-hole arrangement

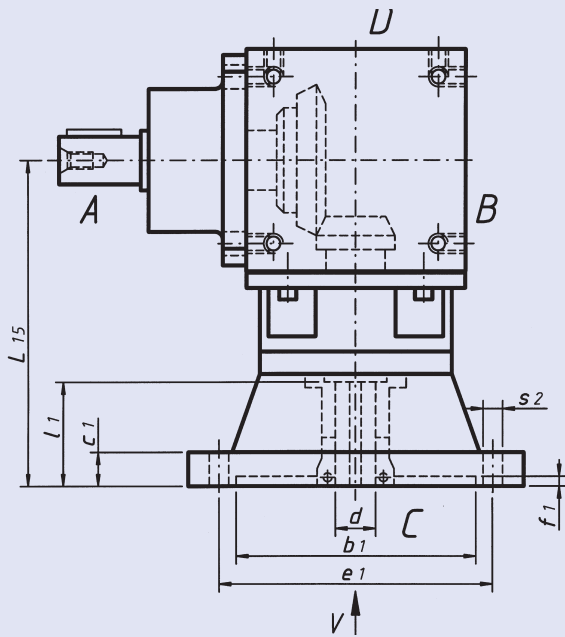

Bauarten / Design

Ba 10

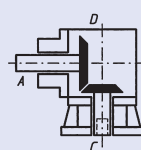

Ba 20

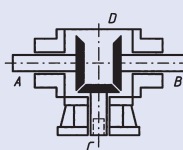

Mögliche Sackloch-Abmessungen

Possible hollow input shaft dimensions

Grösse / Size	230		250		300		370		400	
		l15		l15		l15		l15		l15
19 x 63	X	215	X	230						
24 x 63	X	215	X	230						
28 x 63	X	215	X	230	X	280				
32 x 63	X	215	X	230	X	280				
38 x 81	X	235	X	250	X	280	X	305	X	370
42 x 111					X	310	X	335	X	370
48 x 111					X	310	X	335	X	370
55 x 111							X	335	X	370
60 x 145									X	370

Mögliche Motorflansch-Abmessungen

Possible motor flange dimensions

Grösse Size	Übersetzung Ratio	IEC / DIN	Ø b1	Ø e1	□ a1	Ø a2	s2	c1	f1
230	1 - 6	A140 / B5	95	115		145	4 x M8	12	5
		C140 / B14	95	115		145	4 x Ø 9	12	
		FF130 / B5	110	130	145	160	4 x M8	12	
		FT130 / B14	110	130	145	160	4 x Ø 9	12	
		A160 / B5	110	130		160	4 x M8	12	
		C160 / B14	110	130		160	4 x Ø 9	12	
		FF165 / B5	130	165	145	190	4 x M10	15	
		FT165 / B14	130	165	145	190	4 x Ø 11	15	
		A200 / B5	130	165		200	4 x M10	15	
		C200 / B14	130	165		200	4 x Ø 11	15	
		FF215 / B5	180	215	200	250	4 x M12	18	
		A250 / B5	180	215		250	4 x M12	18	
		FF265 / B5	230	265	242	300	4 x M12	18	
250	1 - 6	A300 / B5	230	265		300	4 x M12	18	5
		FF165 / B5	130	165	145	190	4 x M10	15	
		FT165 / B14	130	165	145	190	4 x Ø 11	15	
		A200 / B5	130	165		200	4 x M10	15	
		C200 / B14	130	165		200	4 x Ø 11	15	
		FF215 / B5	180	215	200	250	4 x M12	18	
		A250 / B5	180	215		250	4 x M12	18	
300	1 - 6	FF265 / B5	230	265	242	300	4 x M12	18	5
		A300 / B5	230	265		300	4 x M12	18	
		FF215 / B5	180	215	200	250	4 x M12	18	
		A250 / B5	180	215		250	4 x M12	18	
		FF265 / B5	230	265	242	300	4 x M12	18	
370	1 - 6	A300 / B5	230	265		300	4 x M12	18	5
		FF300 / B5	250	300	260	350	4 x M16	24	
		A350 / B5	250	300		350	4 x M16	24	
		FF300 / B5	250	300	260	350	4 x M16	24	
		FF350 / B5	300	350	345	400	4 x M16	24	
400	1 - 6	A400 / B5	300	350		400	4 x M16	24	6
		A300 / B5	230	265		300	4 x M12	25	
		A350 / B5	250	300		350	4 x M16	25	
		A450 / B5	350	400		450	8 x M16	25	

Achtung!

Für den Motoranbau bei den Getriebegrößen 230-370 ist eine Paßfedernut in der Motorwelle zwingend vorgeschrieben.

Attention!

For gearbox size 230-370 please use only motor shaft's with keyway