

Einsatzbereiche

Entwickelt und gefertigt für höchste Ansprüche und wirtschaftlich rentablen Einsatz.

- universell einsetzbar
- einbaufreundlich und anpassungsfähig
- maschinengerechte Konstruktion
- kostensparend

Nutzen Sie die in Jahrzehnten bewährten Vorteile des Getriebespezialisten mit dem hohen Qualitätsstandard und dem anerkannten know-how.

- kompaktes Baukastensystem
- hohes Leistungsgewicht
- hoher Wirkungsgrad
- geräuscharm
- wartungsfreundlich

Profitieren auch Sie aus der Erfahrung des weltweiten Einsatzes der **Vogel Getriebe** in den Anlagen und Maschinen unserer Kunden.

Einsatzbereiche

- Allg. Maschinenbau
- Sondermaschinenbau
- Hubwerke - Krananlagen
- Walzwerkantriebe
- Seilbahnanlagen
- Förderanlagen
- Verseilmaschinen
- u. ä.

Where to use it

Developed and manufactured for economic use in demanding industrial applications.

- universally usable
- easy to fit and adaptable
- easy to design and retrofit
- saves cost

Make sure that you use the decadeslong experience of the gearbox specialists with a high standard of quality and the well-recognised know-how.

- compact modular design
- high power to weight ratio
- high efficiency
- quiet running
- easy to maintain

Why don't you also profit from our experience of the worldwide usage of the **Vogel gearbox** range in the machines and plants of our customers.

Applications

- General machinery
- Special purpose machines
- Lifting gear
- Crane installations
- Rolling mills
- Cable installations
- Conveyor drives
- Stranding machinery and many others

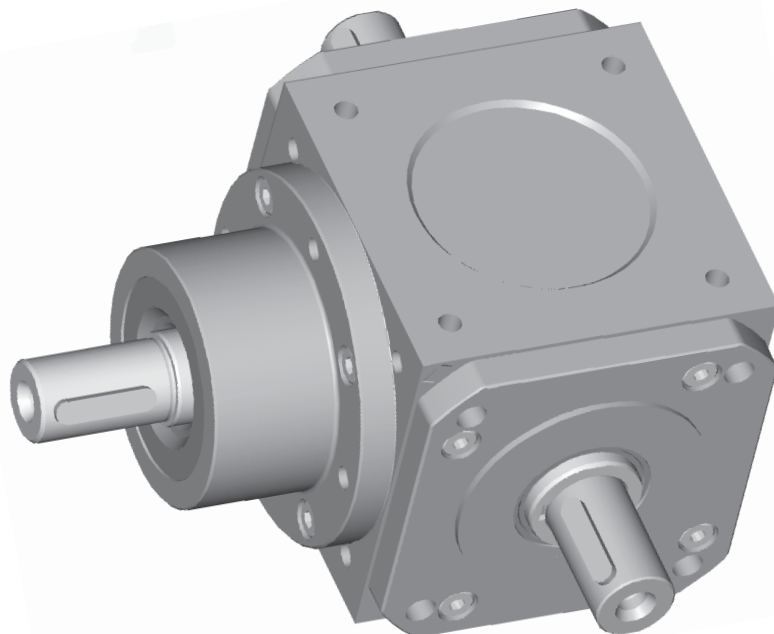

Konstruktiver Aufbau

Das Grundgehäuse besitzt Würfelform, dadurch sind symmetrische Abmessungen gewährleistet. An allen Ein- und Abtriebsseiten sind Zentriermöglichkeiten vorgesehen. Das Gehäuse und die Lagerflansche bestehen aus hochwertigem Grauguss, sind allseitig bearbeitet und mit Befestigungsgewinden versehen. Durch Einsatz robuster Wälzlager ist eine hohe Lebensdauer sichergestellt. Die Konstruktion als Baukastensystem erlaubt die Ausführung als Mehrwellen- Abzweiggetriebe bis zu 6 Wellen. Der Eintritt erfolgt bei d1 ; es kann jedoch auch bei d2 oder d3 eingetrieben werden.

Design

The basic gearbox housing is of cuboid form for dimensional symmetry. All input and output sides have a register for central location. The gearbox housing and bearing flanges are made from high quality grey cast iron and are machined on all sides with tapped mounting holes. The use of robust rolling bearings ensures a high operating life. The modular design system allows designs with multi shaft and takeoff drives with up to 6 shafts. The drive input is usually on shaft d1 , but shaft d2 or d3 can also act as the driver.

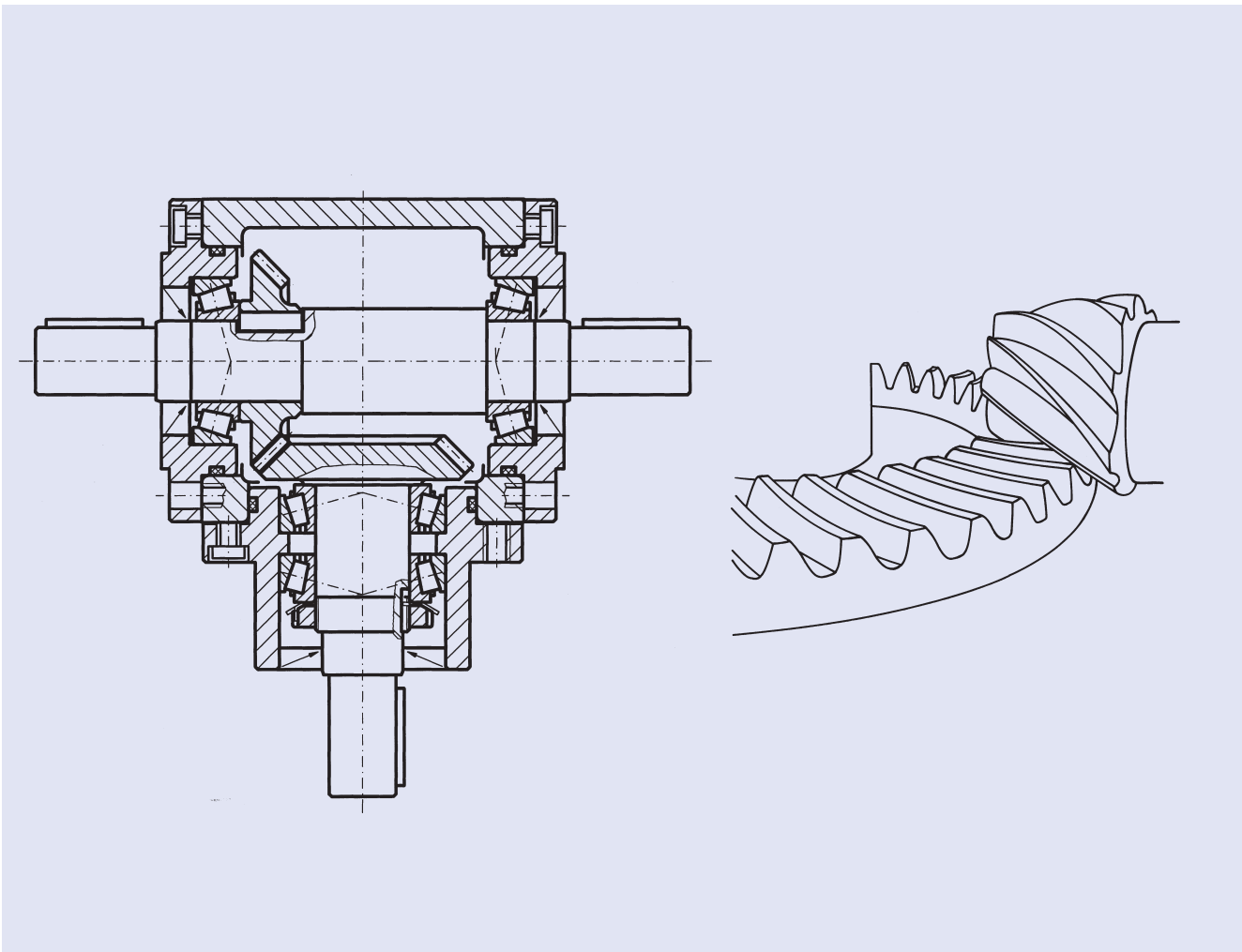

Verzahnung

Die Zahnräder unserer Kegelradgetriebe werden in Klingenberg-Paloid-Spiralverzahnung ausgeführt. Durch die Spiralform der Zähne und die große Überdeckung können sehr hohe Drehmomente übertragen werden. Die Kegelradsätze werden aus legiertem Stahl gefertigt, sind einsatzgehärtet und paarweise geläppt. Durch diese Maßnahmen wird ein optimales Tragbild, eine hohe Lauf-ruhe und ein guter Wirkungsgrad erzielt.

Gearing

The bevel gearboxes incorporate the Klingenberg palloid-spiral gearing. With the spiral tooth form and large contact engagement, high torques can be transmitted. The bevel gear sets are made from high quality alloy steel and they are hardened and lapped in pairs. With these features an optimum tooth marking pattern is achieved, together with very quiet running and good efficiency.

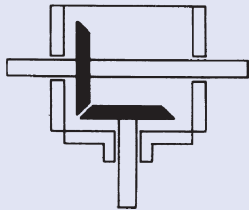
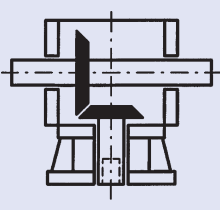
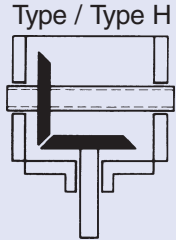
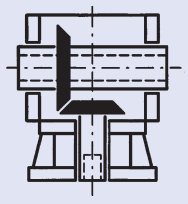
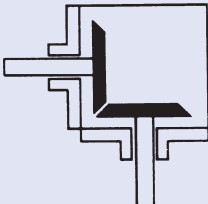
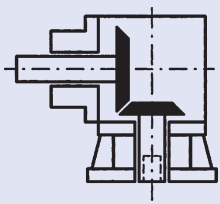
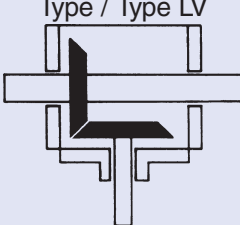
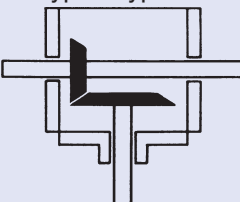
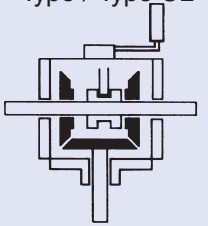
	Übersetzung Ratio	Abtriebsdrehmoment Output torque	Ausführungsform Design description	
<p>Type / Type L</p>  <p>Seite 18</p>	<p>1 : 1 bis 6 : 1 Gr. 50 nur bis 4 : 1</p> <p>1 : 1 to 6 : 1 size 50 only to 4 : 1</p>	<p>von / from 15 Nm</p> <p>bis / from 9000 Nm</p>	<p>mit durchgehender Welle</p> <p>with through shaft</p>	<p>Type / Type ML</p>  <p>Seite 18</p>
<p>Type / Type H</p>  <p>Seite 30</p>	<p>1 : 1 bis 6 : 1 Gr. 50 nur bis 4 : 1</p> <p>1 : 1 to 6 : 1 size 50 only to 4 : 1</p>	<p>von / from 15 Nm</p> <p>bis / from 9000 Nm</p>	<p>mit durchgehender Hohlwelle</p> <p>with hollow throughshaft</p>	<p>Type / Type MH</p>  <p>Seite 30</p>
<p>Type / Type K</p>  <p>Seite 42</p>	<p>1 : 1 bis 6 : 1 Gr. 50 nur bis 4 : 1</p> <p>1 : 1 to 6 : 1 size 50 only to 4 : 1</p> <p>ohne Gr. / without size 500, 600</p>	<p>von / from 15 Nm</p> <p>bis / from 1800 Nm</p>	<p>mit zwei fliegend gelagerten Wellen</p> <p>with two independent bearing mounted shafts</p>	<p>Type / Type MK</p>  <p>Seite 42</p>
<p>Type / Type LV</p>  <p>Seite 50</p>	<p>1 : 1 bis 6 : 1 Gr. 50 nur bis 4 : 1</p> <p>1 : 1 to 6 : 1 size 50 only to 4 : 1</p>	<p>von / from 15 Nm</p> <p>bis / from 9000 Nm</p>	<p>mit verstärkter durchgehender Welle</p> <p>with strengthened through shaft</p>	
<p>Type / Type LS</p>  <p>Seite 58</p>	<p>1 : 1,25 mult. 1 : 1,50 mult. 1 : 1,75 mult. 1 : 2,00 mult. ohne Gr. 50</p> <p>without size 50</p>	<p>von / from 25 Nm</p> <p>bis / from 9000 Nm</p>	<p>mit durchgehender Welle, schnelllaufend</p> <p>with speed increasing through shaft</p>	
<p>Type / Type UL</p>  <p>Seite 62</p>	<p>1,0 : 1 1,5 : 1 2,0 : 1 nur Gr. 1- 4</p> <p>only sizes 1 - 4</p>	<p>von / from 50 Nm</p> <p>bis / from 1800 Nm</p>	<p>Umschaltgetriebe für Drehrichtungsände- rung</p> <p>Reversing gearbox</p>	

Ein- und Abtriebswellen sind mit den Drehrichtungen voneinander abhängig.

The directions from input- and output shaft are interdependent.

Die verschiedenen Möglichkeiten sind an den nachfolgenden Grundbauformen dargestellt.

The different possibilities you can see on the design below.

Mehrwellengetriebe **siehe Seite 72 - 75**

Multi shaft gearboxes please **see page 72 - 75**

Typ / Type K, MK

Ba 10

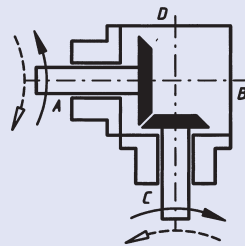

Ba 20

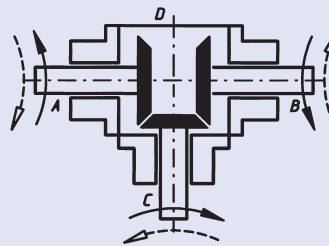

Typ / Type L, ML, LS, LV

Ba 30

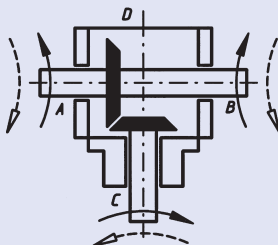

Ba 40

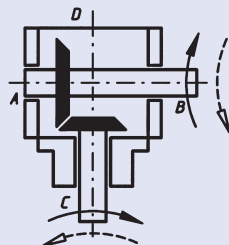

Ba 50

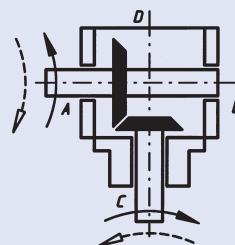

Ba 60

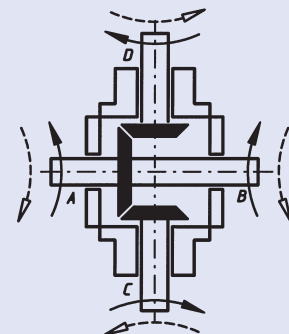

Typ / Type H, MH

Ba 70

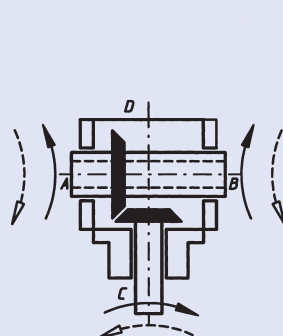

Ba 80

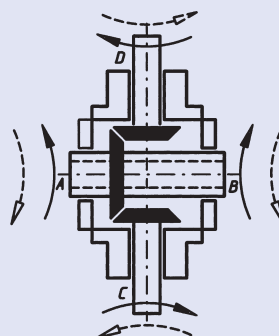

Seitenbezeichnungen / Drehrichtungen

Identification of Sides / Directions of Rotation

Um ein Kegelradgetriebe genau definieren und beschreiben zu können sind einheitliche Standards notwendig. Wichtig hierzu ist die Bezeichnung der einzelnen Seiten der Getriebe, sowie die Lage der Kegelräder und die genaue Definition der Drehrichtungen.

Seitenbezeichnungen

Die Seiten eines Kegelradgetriebes sind mit den **Buchstaben A, B, C, D, E, und F** bezeichnet.

Lage der Kegelräder

Die Lage der Kegelräder ist **Seite C und A**, wobei wir die **Seite C** als **Eintrieb** definieren.

Drehrichtungen

Die Drehrichtungen einzelner Wellenzapfen werden definiert, indem man **von außen auf den Wellenzapfen** schaut. Aus dieser Sicht erfolgt die **Drehrichtungsangabe rechts oder links**.

To describe and define a bevel-gearbox accurately, uniform standards are required. The important points here are a way of identifying each side of a gearbox and the positions of the bevel gears, and clear definition of the directions of rotation.

Identification of sides

The sides of a bevel-gearbox are identified with the **letters A, B, C, D, E and F**. (see drawing below)

Positions of bevel gears

The bevel gears are positioned against **sides C and A**, and **side C** is defined as the **input side**.

Directions of rotation

The direction of rotation of each shaft end is defined as though you were looking **from the outside at the shaft end**. From this viewpoint, the **direction of rotation** is given as **clockwise or counterclockwise**.

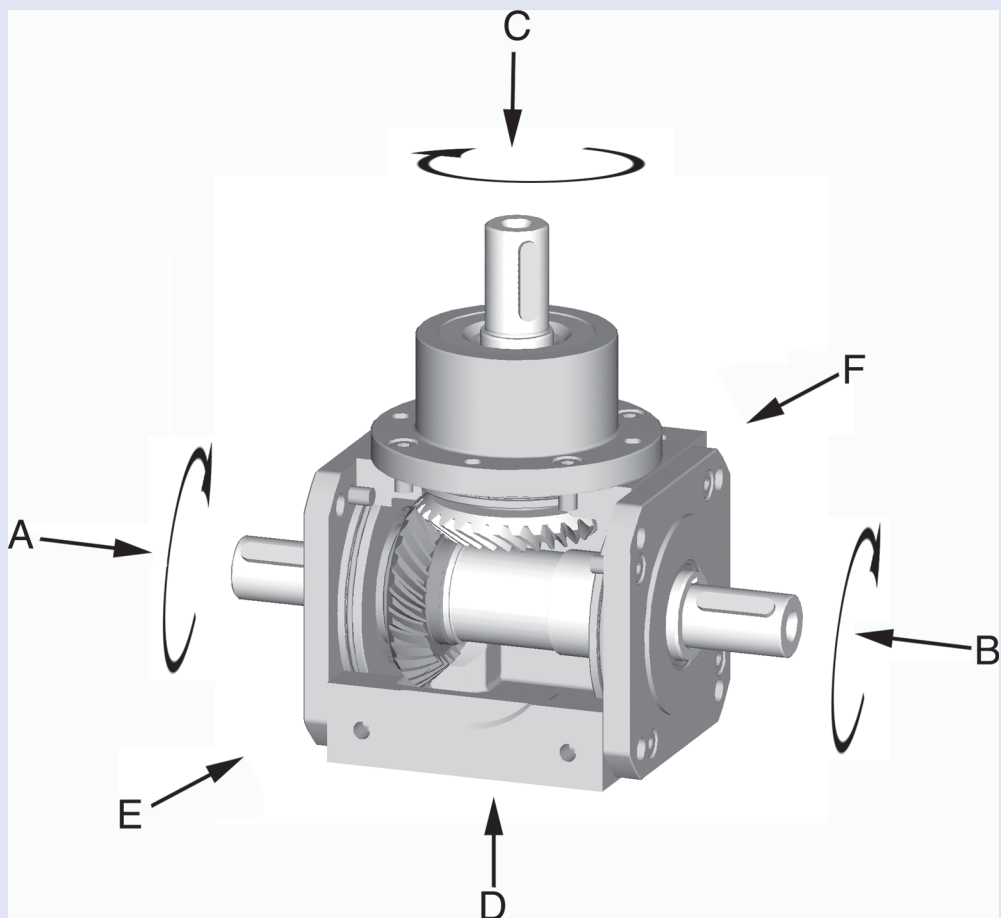

Technical datas

		Gearbox size			
		50	100 - 230	250 - 400	500 + 600
Efficiency η	For nominal input power	$0,85 \leq \eta \leq 0,94$	$0,9 \leq \eta \leq 0,94$	$0,95 \leq \eta \leq 0,96$	$0,96 \leq \eta \leq 0,98$
Housing and flange	Design Material Special design	Cube formed Cast iron EN-GJL-250 (0.6025) or spheroidal graphite iron EN-GJS-400-15 (0.7040) or aluminium G-Al Si 10 Mg (3.1645) Housing and flanges aluminium Cast steel or welded construction Stainless steel Galvanic coating			
Shaft	Design Tolerance Material Special design	Shaft centering DIN 332, page 2 With keyway DIN 6885, page1 j6 resp. k6 C 45 (1.1191) or 42 Cr Mo 4 (1.7225) Stainless steel or chromium coated Shafts without key and keyway Involute spline shaft DIN 5480 and 5482 Spline shaft profile DIN 5463			
Hollow shaft	Design Tolerance Material Special design	With keyway or without keyway and with shrink disc H7 C 45 (1.1191) Stainless steel Involute spline bore DIN 5480 and 5482 Spline shaft bore profile DIN 5463 Cast bronze design			
Bevel gear set	Design Material Special design	Klingelberg Polloid resp. Klingelberg Zyklo-Paloid spiral teeth Optimized for low noise and high torque Milled teeth, case-hardened and lapped in pairs 16 Mn Cr 5 (1.7131) or 17 Cr Ni Mo 6 (1.6587) To noise or torque optimized gearset ZPG-gearset (case-hardened and teeth fine grinded to quality 4)			
Connection hub to shaft	Design	Force-fitted resp. form-fitted Parts are shrunk fitted			
Oil seals	Design Material Special design	With or without dust lip DIN 3760 NBR or Viton Special oil seals, PTFE, Labyrinth seals			
Bearings	Design Special design	Ball bearings and taper roller bearings Reinforced bearings for higher radial and axial load			
Lubrication	Design Mounting position Filling capacity Special design	DIN 51502 mineral grease or oil, speed dependent Advised with your order Dependent to mounting position, see maintenance manual Mineral and synthetic special grease and oil lubrication Grease and oil for food processing Special high or deep temperatur oil Forced oil lubrication			
Surface treatment	Design Color shade Special design	Under coat RAL 7035 light-grey Under coat in special colours Galvanic coating			
Noise		approx. 75 dB(A) in 1m distance			
Bearing life time		approx. 20 000 hours by 1500 rpm			
Max. gearbox temperatur		80° C (176° F)			

Übersetzungsplan Verdrehflankenspiel

Ratio plan Backlash

Typ / Type L, ML, H, MH, K, MK, LV

Standard - Übersetzungen / Standard ratios													
Getr. - Grösse / Size	1		1,5		2		3		4		5		6
50	X		X		X		X		X				
100 - 600	X		X		X		X		X		X		X
Sonder - Übersetzungen / Non - standard ratios													
Getr. - Grösse / Size		1,25		1,75		2,5		3,5		4,5		5,5	
50		X		X		X		X					
100 - 600		X		X		X		X		X		X	

Typ / Type LS

Standard - Übersetzung / Standard ratios				
Getr. - Grösse / Size	1		1,5	2
100 - 600			X	X
Sonder - Übersetzung / Non - standard ratios				
Getr. - Grösse / Size		1,25		1,75
100 - 600		X		X

Typ / Type UL

Standard - Übersetzung / Standard ratios				
Getr. - Grösse / Size	1		1,5	2
1 - 4	X		X	X
Sonder - Übersetzung / Non - standard ratios				
Getr. - Grösse / Size		1,25		1,75
1 - 4		X		X

Alle genannten Übersetzung sind mathematisch genau.
Andere Übersetzungen auf Anfrage.

All ratios are mathematical exact.
Other ratios on request.

Verdrehflankenspiel

Das Verdrehspiel wird mit 2% vom Getriebenenennmoment gemessen. Wir bieten 3 Qualitätsstandards an. Qualitätsstufe 1 sind kostenlos, für die Stufen 2 + 3 ist ein Aufpreis erforderlich. Bitte anfragen.

Backlash

The backlash we measure with 2% from nominal output torque. We offer 3 quality standards. Quality standard 1 ar free of charge, for quality standards 2 + 3 we have additional price. Please request.

Stufe	Verdrehspiel / Backlash	Bestellangaben / Order informations
1	Standard max. 10' / Backlash max. 10 arcmin	keine / none
2	Spielarme Ausführung max. 7' / Low backlash max. 7 arcmin Die Einflankenabwärtzabweichung beträgt bei dieser Ausführung F'i max. = 450 The runout error for this application is F'i max. = 450 arcsec	spielarme Ausführung max. 7' / low backlash max. 7 arcmin
3	Spielarme Ausführung max. 4' / Low backlash max. 4 arcmin Die Einflankenabwärtzabweichung beträgt bei dieser Ausführung F'i max. = 250 The runout error for this application is F'i max. = 250 arcsec	spielarme Ausführung max. 4' / low backlash max. 4 arcmin geschliffener Radsatz / ZPG gearset

Verdrehspiel und Einflankenwärtzabweichung können wir mit einem Getriebezertifikat nachweisen.

For backlash and runout error we can give you a certificate.

Einsatzbedingungen

Bei der Berechnung der max. geforderten Einsatzleistung P der anzutreibenden Maschine müssen folgende Einsatzbedingungen beachtet werden:

c₁ = Stossfaktor in Abhängigkeit von der Anzahl der Anläufe pro Stunde und der Betriebsdauer

c₂ = Umgebungstemperatur

Die geforderte Eingangsleistung P errechnet sich wie folgt:

$$P = P_1 \times c_1 \times c_2 \text{ [KW]}$$

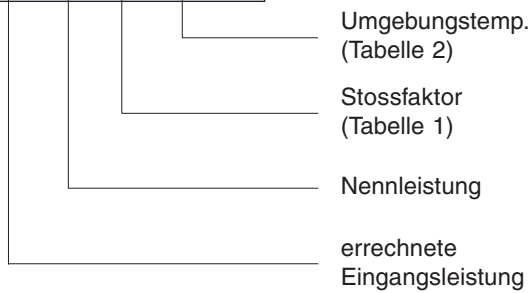

How to use it

When calculating the maximum required input power P of the machine to be driven, the following application conditions have to be observed:

c₁ = Shock factor - this depends on the “starts per hour” and on the “duration of operation”

c₂ = Ambient temperature the required input power P can then be calculated as follows:

$$P = P_1 \times c_1 \times c_2 \text{ [KW]}$$



Tabelle 1 / Table 1



Betriebsart der Arbeitsmaschine

I gleichförmig (Md₂+10%) keine zu beschleunigenden Massen.

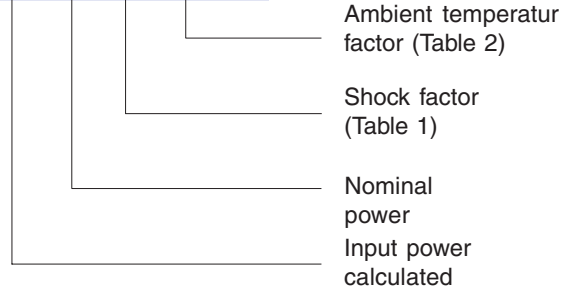
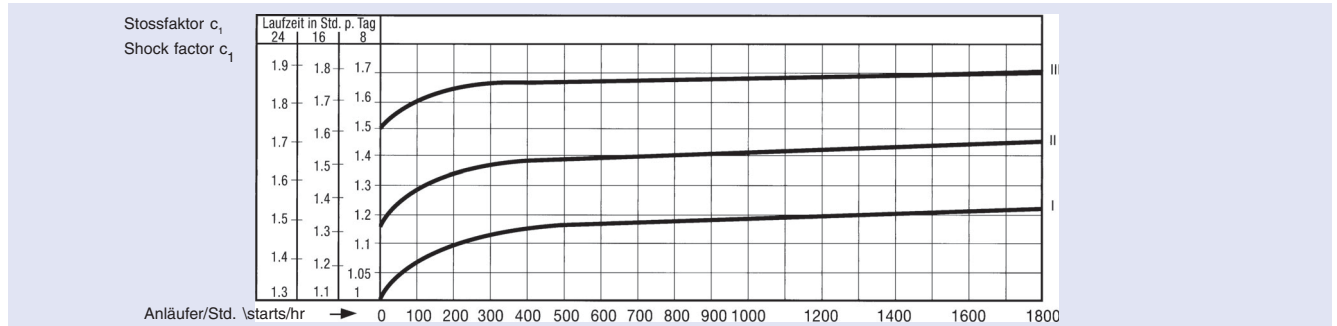
II mittlere Stösse kurzzeitige Überlastung (Md2 + 25%) grösser zu beschleunigende Massen.

III starke Stösse kurzzeitige Überlastung (Md2 + 100%) sehr grosse zu beschleunigende Massen.

Operating mode of the machine

I uniformly (torque change +10%) no masses to be accelerated.

II medium shocks short term overload (torque change +25%) larger masses to be accelerated.

III heavy shocks short term overload (torque change +100%) very large masses to be accelerated.

Tabelle 2 / Table 2

Umgebungstemperatur c ₂ Ambient temperature c ₂	Faktor Factor
10° C	1,0
20° C	1,0
30° C	1,1
40° C	1,2
50° C	1,4

Auswahl der Getriebegrösse

Aus der errechneten Eingangsleistung P [KW] der anzutreibenden Maschine errechnet sich das Abtriebsmoment Md₂ des **Vogel Getriebes**.

n₂ = Abtriebsdrehzahl des Getriebes [min⁻¹].

$$Md_2 = \frac{9550 \times P \times \eta(0,95)}{n_2} \text{ [Nm]}$$

Mit Md₂ und i kann in der folgenden Tabelle die Getriebegrösse bestimmt werden.

Selecting the right size

From the calculated input power P [KW] of the machine to be driven, the output torque T₂ of the **Vogel gearbox** can be found.

n₂ = output speed of the gearbox [rpm]

$$T_2 = \frac{9550 \times P \times \eta(0,95)}{n_2} \text{ [Nm]}$$

With T₂ and i in the following table the size can be found.

Inbetriebnahme

Alle Getriebe werden mit Fett- bzw. Ölfüllung geliefert. Bei Ölfüllung wird der Entlüftungsfiter separat mitgeliefert und muss vom Kunden montiert werden.

Getriebe mit Fettfüllung

Diese Getriebe sind nahezu wartungsfrei. Bei Einschichtbetrieb genügt eine Überprüfung nach fünf Jahren.

Ölwechsel

Erster Ölwechsel nach 500 Betriebsstunden; weitere Ölwechsel nach jeweils 3000 Betriebsstunden.

Empfohlene Fettsorten

Fuchs
Renolin SO-GFB

oder gleichwertige Fette anderer Hersteller

Setting up the drive

All gearboxes are supplied grease or oil filled. With oil filled gearboxes the breather screw with filter is supplied loose and must be fitted upon installation.

Gearboxes with grease filling

These gearboxes are virtually maintenance free. Under normal single shift operations an inspection after five years is sufficient.

Oil change

First oil change after 500 operating hours, thereafter every 3000 operating hours.

Recommended greases

Klüber
Microlube GB00

or greases of equal quality from other suppliers.

Empfohlene Ölsorten

Shell	Fuchs	Mobil	Klüber
Omala 150	Renolin CLP 150	Mobilgear 629	Klüberoil GEM1 - 150

oder gleichwertige Öle anderer Hersteller

or oil of equal quality from other suppliers.

Schmiermittelmenge und Getriebegewicht für Standardgetriebe

Getriebegrösse Gearbox size	50	100	200	230	250	300	370	400	500	600
Gewicht (Kg) Bauart Weight (Kg) Design	1,7	5	12,5	18	25	45	70	100	200	400
Schmiermittelmenge (Kg) Lubricant quantity (Kg)	0,07	0,15	0,4	0,6	0,8	2	3,5	5	13,5	30

Lubricant quantities and weight of standard gear-boxes

Die Gewichts- und Mengenangaben sind ca.-Werte. Für die Ölmenge ist der Ölstand im Ölschauglas massgebend.

The weight and quantity data are appx. values. For the oil quantity, the oil sight glass is relevant.

Schmierung

Für die Schmierungsart (Fett-, Ölschmierung bzw. Einspritzschmierung) ist die Umfangsgeschwindigkeit der Ke- gelräder massgebend.

Mit folgendem Diagramm kann die Schmierungsart bestimmt werden.

Lubrication

The type of lubrication (grease, oil or forced lubrication) is dependent on the surface velocity of bevel gears.

The following diagram determines the type of lubrication.

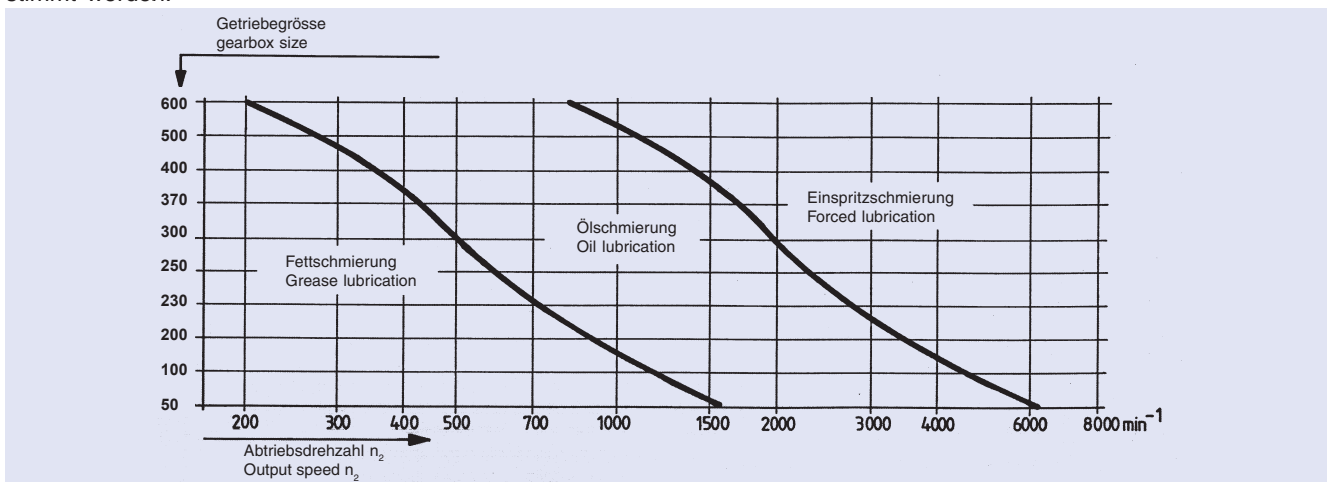

Einspritzschmierung: Auslegung je nach Einsatzfall.
- bitte anfragen -

Forced oil lubrication: Specification dependent on application.
- please enquire -

Typ / Type L

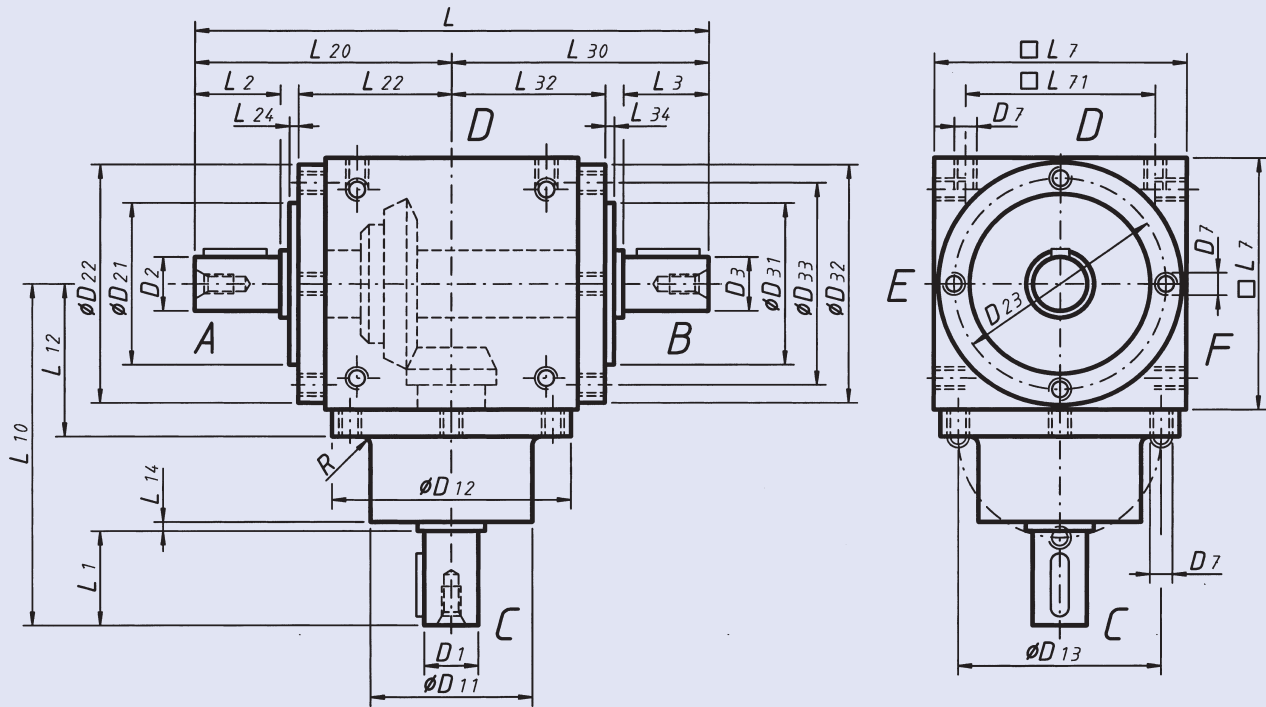

Typ / Type ML

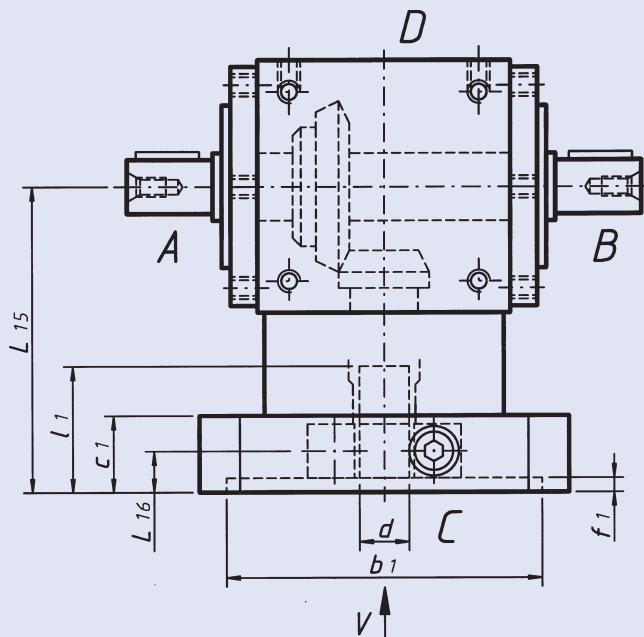

Ansicht / View V:

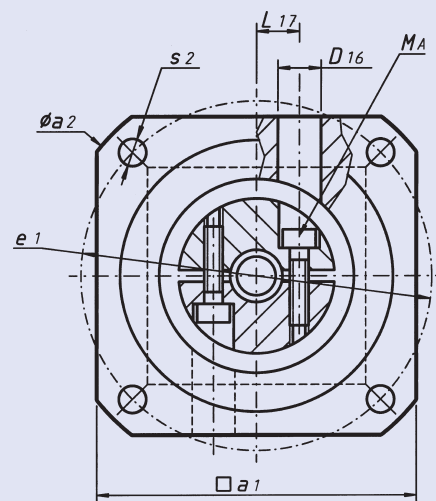

Typ / Type L

Grösse Size	Übersetzung Ratio	D1	D2	D3	D7	D11	D12	D13	D21	D22	D23	D31	D32	D33
50	1 - 2	12 _{J6}	12 _{J6}	12 _{J6}	M6	44 _{T7}	64,5	54	44 _{T7}	64,5	54	44 _{T7}	64,5	54
	3 + 4													

Grösse Size	Übersetzung Ratio	L	L1	L2	L3	L7	L10	L12	L14	L20	L22	L24
50	1 - 2	144	26	26	26	65	100	42	2	72	42	2
	3 + 4						115					

Grösse Size	Übersetzung Ratio	L30	L32	L34	L71	R	Passfeder D1 Keyway D1	Passfeder D2 + D3 Keyway D2 + D3
50	1 - 2	72	42	2	45	0,8	4 x 4 x 20	4 x 4 x 20
	3 + 4							

Typ / Type ML

Grösse Size	Übersetzung Ratio	d G7	l1	b1	e1	a1	a2	s2
50	1 - 4	9	23	70	85	75	100	4 x Ø 7 / M6
		11	26	80	100	90	120	4 x Ø 7 / M6
		14	33	95	115	115	140	4 x Ø 9 / M8

Grösse Size	Übersetzung Ratio	f1	c1	D16	L15	L16	L17
50	1 - 4	4,5	16	8,5	90	9,5	10

Bauarten Typ / Design Type L

Bauarten Typ / Design Type ML

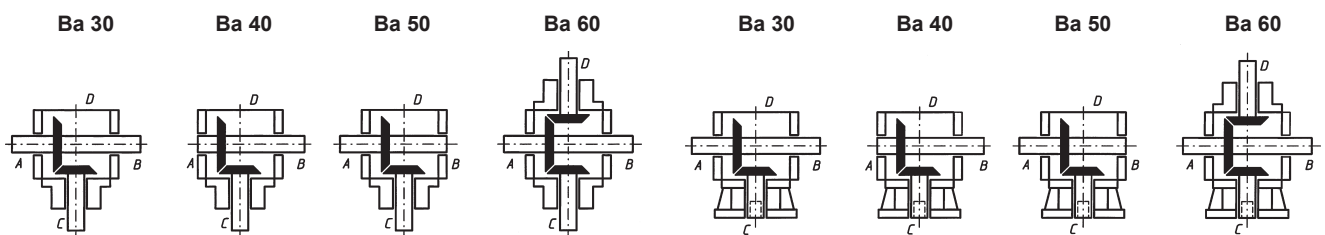

Typ / Type L

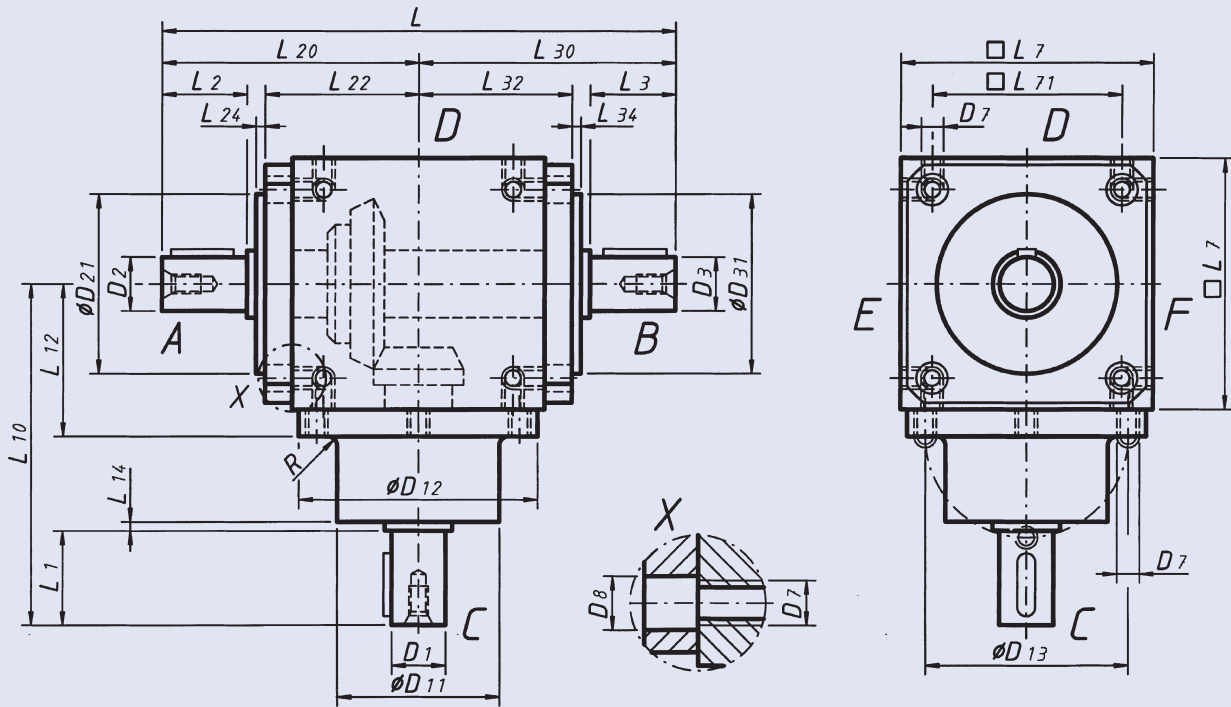

Typ / Type ML

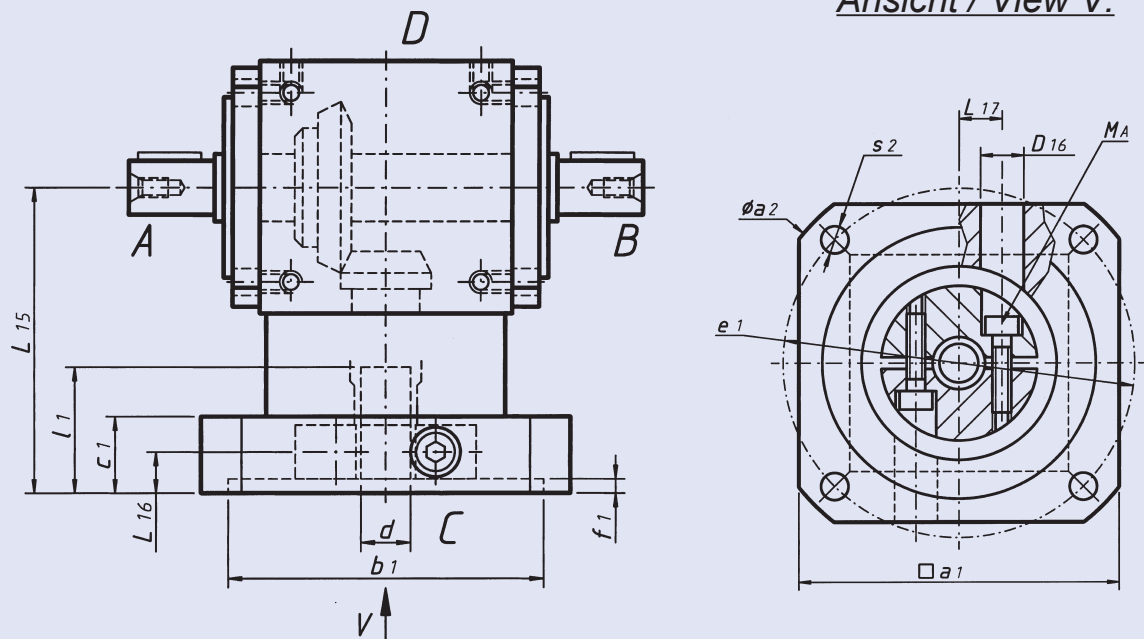

Typ / Type L

Grösse Size	Übersetzung Ratio	D1	D2	D3	D7	D8	D11	D12	D13	D21	D31	L	L1	L2	L3
100	1 - 2	18 _{j6}	18 _{j6}	18 _{j6}	M8	9	60 _{f7}	89 _{f7}	75	60 _{f7}	60 _{f7}	190	35	35	35
	3 + 4	15 _{j6}											30		
	5 + 6	12 _{j6}											25		
200	1 - 2	25 _{j6}	25 _{j6}	25 _{j6}	M10	11	80 _{f7}	119 _{f7}	100	80 _{f7}	80 _{f7}	244	45	45	45
	3 + 4	20 _{j6}											40		
	5 + 6	15 _{j6}											30		

Grösse Size	Übersetzung Ratio	L7	L10	L12	L14	L20	L22	L24	L30	L32	L34	L71	R	Passfeder D1 Keyway D1	Passfeder D2+D3 Keyway D2+D3
100	1 - 2	90	122	55	2	95	55	3	95	55	3	70	1	6 x 6 x 25	6 x 6 x 25
	3 + 4		127											5 x 5 x 20	
	5 + 6		122											4 x 4 x 16	
200	1 - 2	120	162	75	2	122	72	3	122	72	3	100	1	8 x 7 x 36	8 x 7 x 36
	3 + 4		157											6 x 6 x 30	
	5 + 6		147											5 x 5 x 20	

Typ / Type ML

Grösse Size	Übersetzung Ratio	d G7	l1	b1	e1	a1	a2	s2
100	1 - 6	9	23	70	85	95	105	4 x Ø 7 / M6
		11	26	80	100	95	120	4 x Ø 7 / M6
		14	35	95	115	115	140	4 x Ø 9 / M8
		19	45	110	130	130	160	4 x Ø 9 / M8
200	1 - 6	11	26	80	100	125	140	4 x Ø 7 / M6
		14	35	95	115	125	140	4 x Ø 9 / M8
		19	45	110	130	130	160	4 x Ø 9 / M8
		24	55	110	130	140	160	4 x Ø 9 / M8
		28	65	130	165	140	190	4 x Ø 11/M10

Grösse Size	Übersetzung Ratio	f1	c1	D16	L15	L16	L17
100	1 - 6	5	22	10	125	13	12,5
200	1 - 6	5	25	14	145	15	16,5

Bauarten Typ / Design Type L

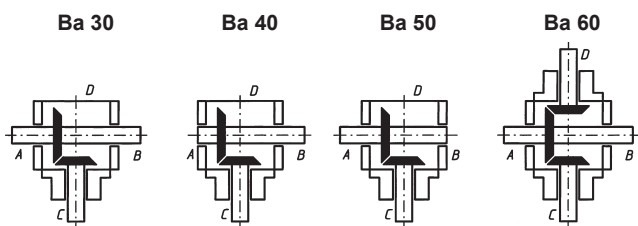

Bauarten Typ / Design Type ML

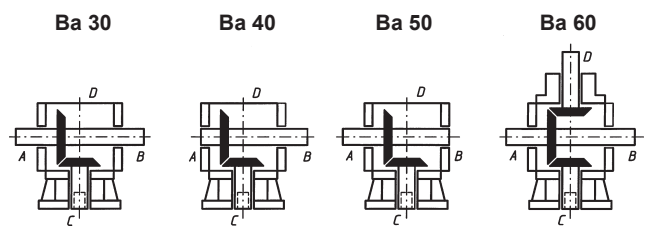

Ansicht / View V:

Vierkant-Flansch / Square flange

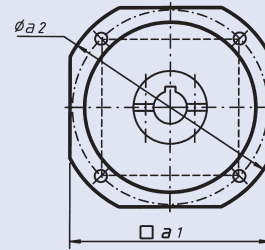

Bohrbild bei 4 Anschraublöchern
4-hole arrangement

Runder Flansch / Round flange

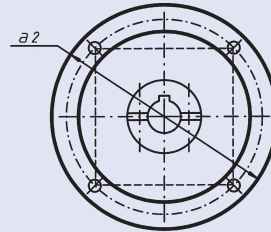

Bohrbild bei 4 Anschraublöchern
4-hole arrangement

Runder Flansch / Round flange

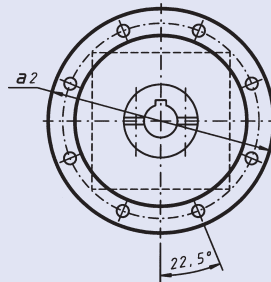

Bohrbild bei 8 Anschraublöchern
8-hole arrangement

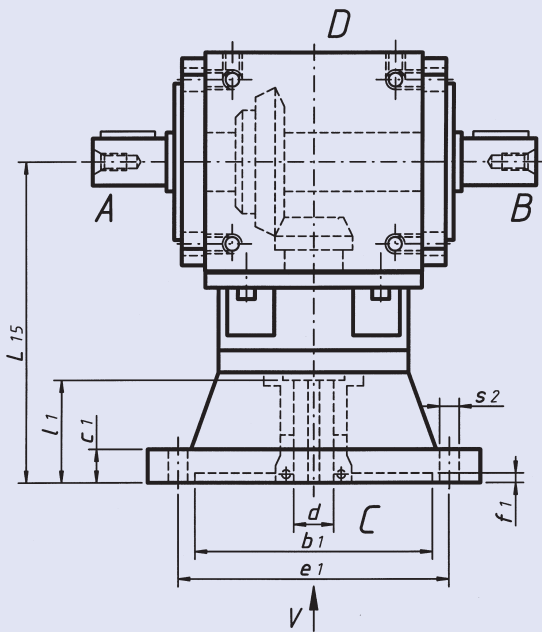

Bauarten / Design

Ba 30

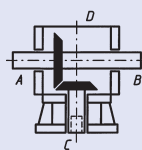

Ba 40

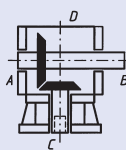

Ba 50

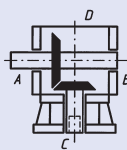

Ba 60

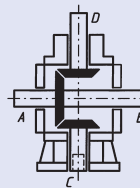

Mögliche Sackloch-Abmessungen

Possible hollow input shaft dimensions

Grösse / Size	230		250		300		370		400	
		I15		I15		I15		I15		I15
19 x 63	X	215	X	230						
24 x 63	X	215	X	230						
28 x 63	X	215	X	230	X	280				
32 x 63	X	215	X	230	X	280				
38 x 81	X	235	X	250	X	280	X	305	X	370
42 x 111					X	310	X	335	X	370
48 x 111					X	310	X	335	X	370
55 x 111							X	335	X	370
60 x 145									X	370

Mögliche Motorflansch-Abmessungen

Possible motor flange dimensions

Grösse Size	Übersetzung Ratio	IEC / DIN	Ø b1	Ø e1	□ a1	Ø a2	s2	c1	f1
230	1 - 6	A140 / B5	95	115		145	4 x M8	12	5
		C140 / B14	95	115		145	4 x Ø 9	12	
		FF130 / B5	110	130	145	160	4 x M8	12	
		FT130 / B14	110	130	145	160	4 x Ø 9	12	
		A160 / B5	110	130		160	4 x M8	12	
		C160 / B14	110	130		160	4 x Ø 9	12	
		FF165 / B5	130	165	145	190	4 x M10	15	
		FT165 / B14	130	165	145	190	4 x Ø 11	15	
		A200 / B5	130	165		200	4 x M10	15	
		C200 / B14	130	165		200	4 x Ø 11	15	
		FF215 / B5	180	215	200	250	4 x M12	18	
		A250 / B5	180	215		250	4 x M12	18	
		FF265 / B5	230	265	242	300	4 x M12	18	
A300 / B5	230	265		300	4 x M12	18			
250	1 - 6	FF165 / B5	130	165	145	190	4 x M10	15	5
		FT165 / B14	130	165	145	190	4 x Ø 11	15	
		A200 / B5	130	165		200	4 x M10	15	
		C200 / B14	130	165		200	4 x Ø 11	15	
		FF215 / B5	180	215	200	250	4 x M12	18	
		A250 / B5	180	215		250	4 x M12	18	
		FF265 / B5	230	265	242	300	4 x M12	18	
300	1 - 6	A300 / B5	230	265		300	4 x M12	18	5
		FF215 / B5	180	215	200	250	4 x M12	18	
		A250 / B5	180	215		250	4 x M12	18	
		FF265 / B5	230	265	242	300	4 x M12	18	
		A300 / B5	230	265		300	4 x M12	18	
370	1 - 6	FF300 / B5	250	300	260	350	4 x M16	24	6
		A350 / B5	250	300		350	4 x M16	24	
		FF350 / B5	300	350	345	400	4 x M16	24	
		A400 / B5	300	350		400	4 x M16	24	
		FF265 / B5	230	265	242	300	4 x M12	18	
A300 / B5	230	265		300	4 x M12	18			
400	1 - 6	A300 / B5	230	265		300	4 x M12	25	7
		A350 / B5	250	300		350	4 x M16	25	
		A400 / B5	300	350		400	4 x M16	25	
		A450 / B5	350	400		450	8 x M16	25	

Achtung!

Für den Motoranbau bei den Getriebegrößen 230-370 ist eine Paßfedernut in der Motorwelle zwingend vorgeschrieben.

Attention!

For gearbox size 230-370 please use only motor shaft's with keyway

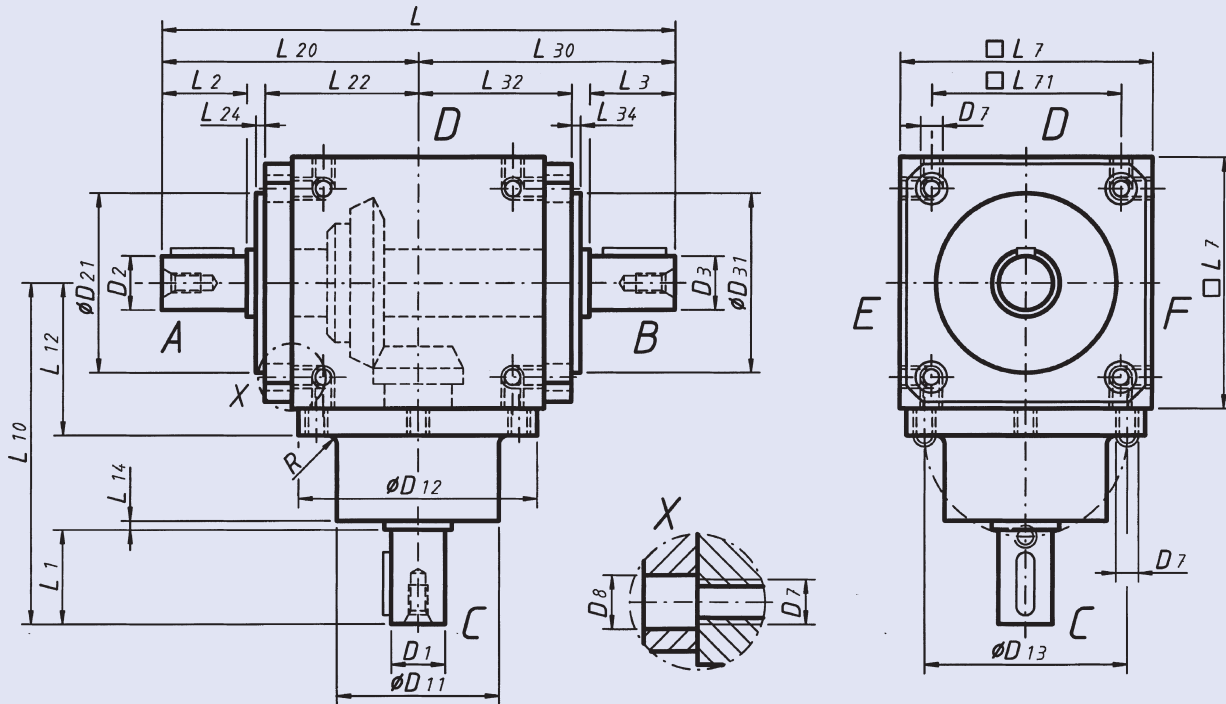

Bauarten / Design

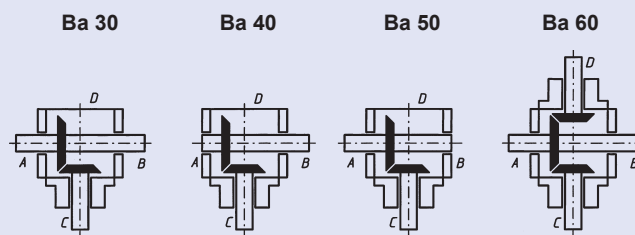

Abmessungen Typ L 230 - 400

Dimensions Type L 230 - 400

Grösse Size	Übersetzung Ratio	D1	D2	D3	D7	D8	D11	D12	D13	D21	D31	L	L1	L2	L3
230	1 - 2	32 _{j6}	32 _{j6}	32 _{j6}	M10	11	95 _{f7}	135 _{f7}	115	100 _{f7}	100 _{f7}	274	50	50	50
	3 + 4	28 _{j6}													
	5 + 6	24 _{j6}													
250	1 - 2	35 _{j6}	35 _{j6}	35 _{j6}	M12	13,5	110 _{f7}	156 _{f7}	135	110 _{f7}	110 _{f7}	320	60	60	60
	3 + 4	28 _{j6}											55		
	5 + 6	24 _{j6}											50		
300	1 - 2	42 _{j6}	42 _{j6}	42 _{j6}	M12	13,5	120 _{f7}	198 _{f7}	175	120 _{f7}	120 _{f7}	406	80	80	80
	3 + 4	35 _{j6}											68		
	5 + 6	28 _{j6}											55		
370	1 - 2	55 _{j6}	55 _{j6}	55 _{j6}	M16	17,5	150 _{f7}	225 _{f7}	200	150 _{f7}	150 _{f7}	460	90	90	90
	3 + 4	40 _{j6}					140 _{f7}						80		
	5 + 6	35 _{j6}					70								
400	1 - 2	60 _{j6}	60 _{j6}	60 _{j6}	M16	17,5	160 _{f7}	258 _{f7}	230	180 _{f7}	180 _{f7}	570	110	110	110
	3 + 4	50 _{j6}											90		
	5 + 6	45 _{j6}													

Grösse Size	Übersetzung Ratio	L7	L10	L12	L14	L20	L22	L24	L30	L32	L34	L71	R	Passfeder D1 Keyway D1	Passfeder D2+D3 Keyway D2+D3
230	1 - 2	140	180	83	2	137	82	3	137	82	3	110	2	10 x 8 x 45	10 x 8 x 45
	3 + 4		195											8 x 7 x 40	
	5 + 6		8 x 7 x 40												
250	1 - 2	160	212	95	2	160	95	3	160	95	3	120	2	10 x 8 x 45	10 x 8 x 45
	3 + 4		227											8 x 7 x 45	
	5 + 6		222											8 x 7 x 40	
300	1 - 2	200	273	120	3	203	117	4	203	117	4	160	3	12 x 8 x 60	12 x 8 x 60
	3 + 4		261		2									10 x 8 x 45	
	5 + 6		248		8 x 7 x 45										
370	1 - 2	230	305	135	2	230	132	6	230	132	6	180	5	16 x 10 x 80	16 x 10 x 80
	3 + 4		310											12 x 8 x 60	
	5 + 6		300											10 x 8 x 50	
400	1 - 2	260	380	150	5	285	150	22	285	150	22	220	5	18 x 11 x 90	18 x 11 x 90
	3 + 4		360										14 x 9 x 70		
	5 + 6		10										14 x 9 x 70		

Typ / Type L

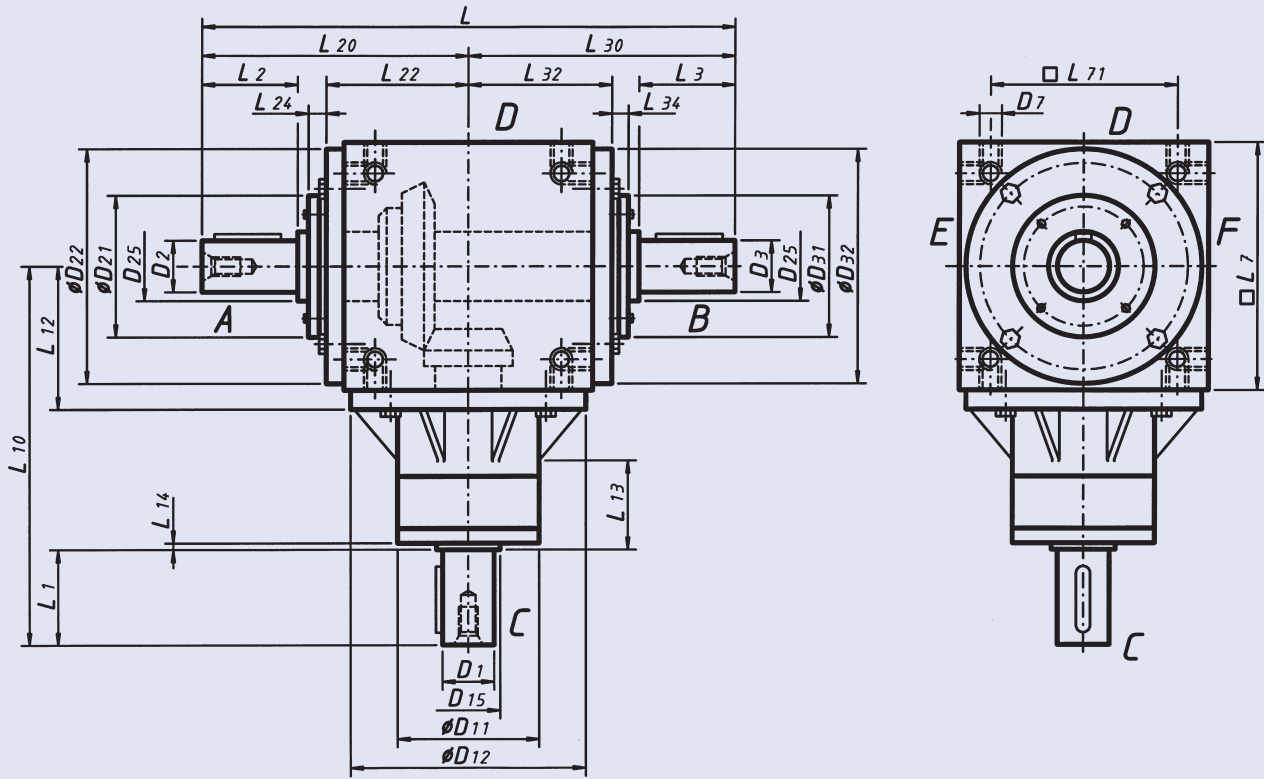

Typ / Type ML

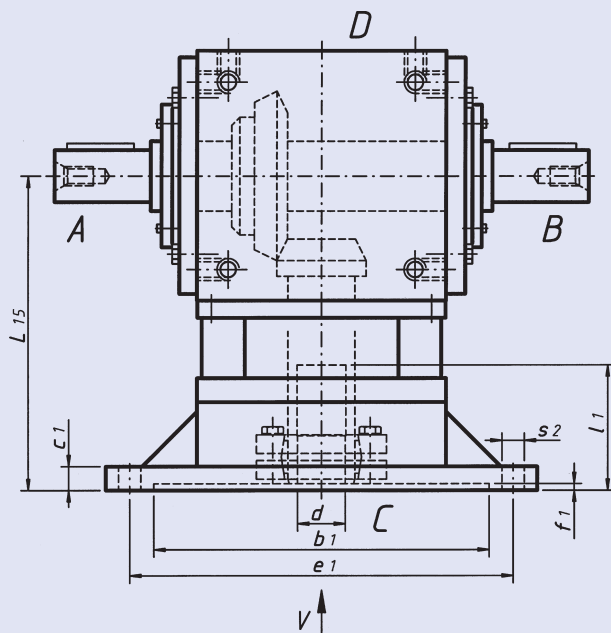

Ansicht / View V:

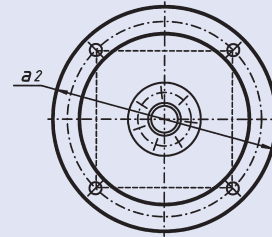

Bohrbild bei 4 Anschraublöchern
4-hole arrangement

Ansicht / View V:

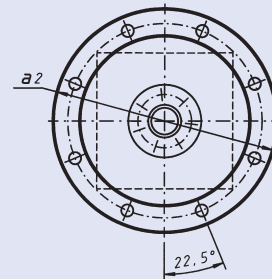

Bohrbild bei 8 Anschraublöchern
(ab Motorbaugröße 225)
8-hole arrangement
(from motor size 225)

Typ / Type L

Grösse Size	Übersetzung Ratio	D1	D2	D3	D7	D11	D12	D15	D21	D22	D25	D31	D32
500	1 - 2	80 _{j6}	80 _{j6}	80 _{j6}	M20	250	345 _{f7}	85	200	345 _{f7}	90	200	345 _{f7}
	3 + 4	65 _{j6}						70					
	5 + 6	55 _{j6}											

Grösse Size	Übersetzung Ratio	L	L1	L2	L3	L7	L10	L12	L13	L14	L20	L22	L24
500	1 - 2	820	170	170	170	350	570	202	90	5	410	200	25
	3 + 4		140										
	5 + 6		110										

Grösse Size	Übersetzung Ratio	L30	L32	L34	L71	Passfeder D1 Keyway D1	Passfeder D2 + D3 Keyway D2 + D3
500	1 - 2	410	202	23	285	22 x 14 x 160	22 x 14 x 160
	3 + 4					18 x 11 x 125	
	5 + 6					16 x 10 x 90	

Typ / Type ML

Grösse Size	Übersetzung Ratio	d G7	l1	b1	e1	a2	s2	f1	c1	L15
500	1 - 4	42	115	250	300	350	4 x M16	7	25	440
		55	115	300	350	400	4 x M16			
		60	145	350	400	450	8 x M16			
	5 - 6	65	145	450	500	550	8 x M16	415		

Bauarten Typ / Design Type L

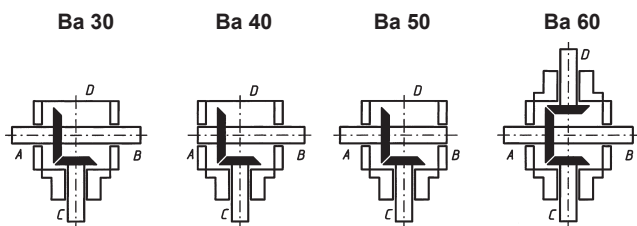

Bauarten Typ / Design Type ML

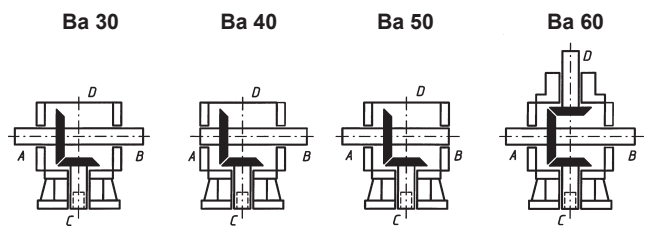

Typ / Type L

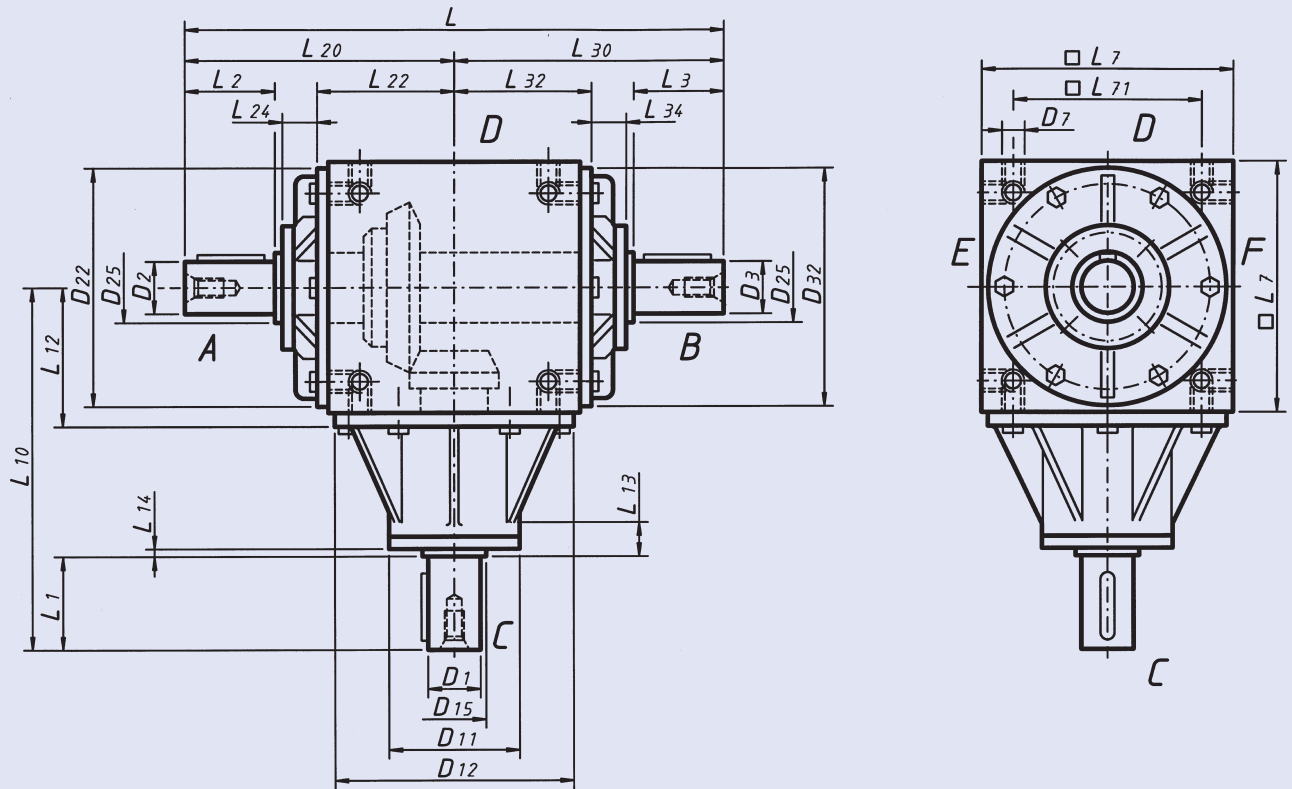

Typ / Type ML

Auf Anfrage
On request

Grösse Size	Übersetzung Ratio	D1	D2	D3	D7	D11	D12	D15	D22	D25	D32
600	1 - 2	90 _{j6}	90 _{j6}	90 _{j6}	M20	190	445 ₁₇	95	445 ₁₇	95	445 ₁₇
	3 + 4	75 _{j6}						75			
	5 + 6	60 _{j6}									

Grösse Size	Übersetzung Ratio	L	L1	L2	L3	L7	L10	L12	L13	L14	L20	L22	L24
600	1 - 2	940	150	150	150	450	600	250	33	5	470	245	70
	3 + 4		120				570						
	5 + 6		110				530						

Grösse Size	Übersetzung Ratio	L30	L32	L34	L71	Passfeder D1 Keyway D1	Passfeder D2 + D3 Keyway D2 + D3
600	1 - 2	470	245	70	360	25 x 14 x 140	25 x 14 x 145
	3 + 4					20 x 12 x 110	
	5 + 6					18 x 11 x 100	

Bauarten / Design

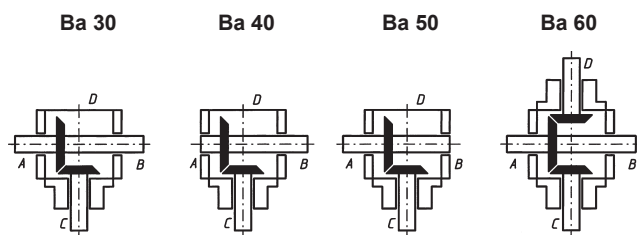

Typ / Type H

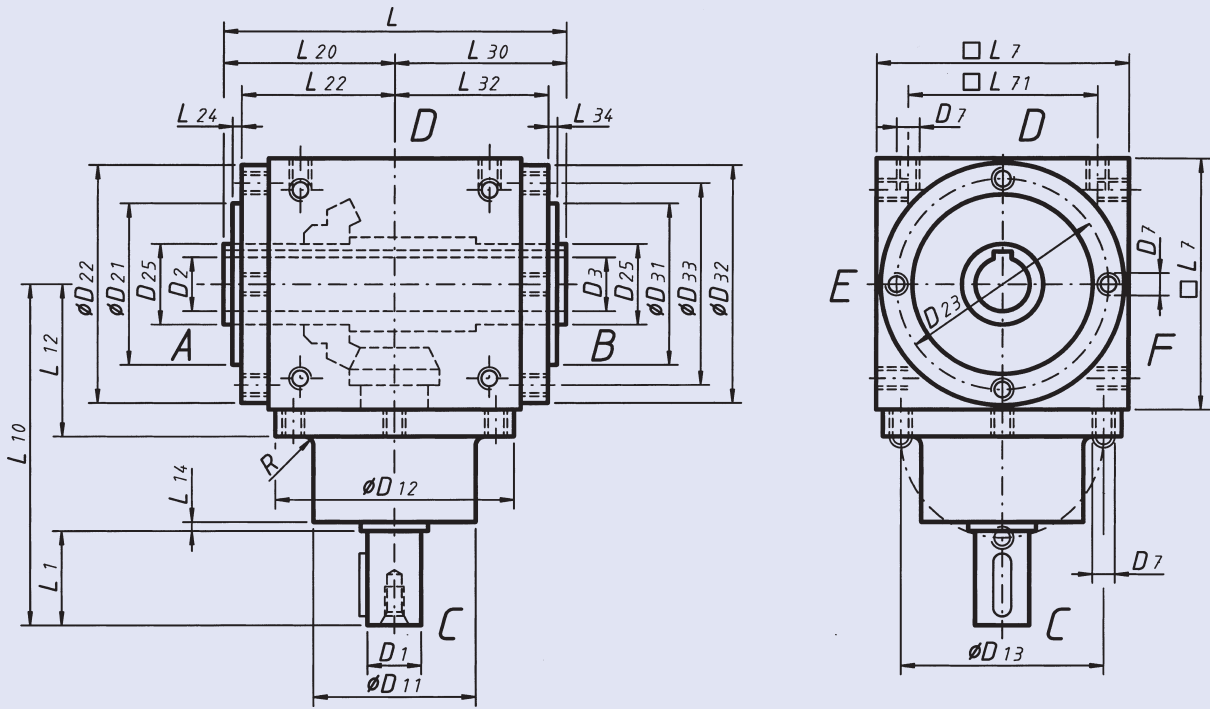

Typ / Type MH

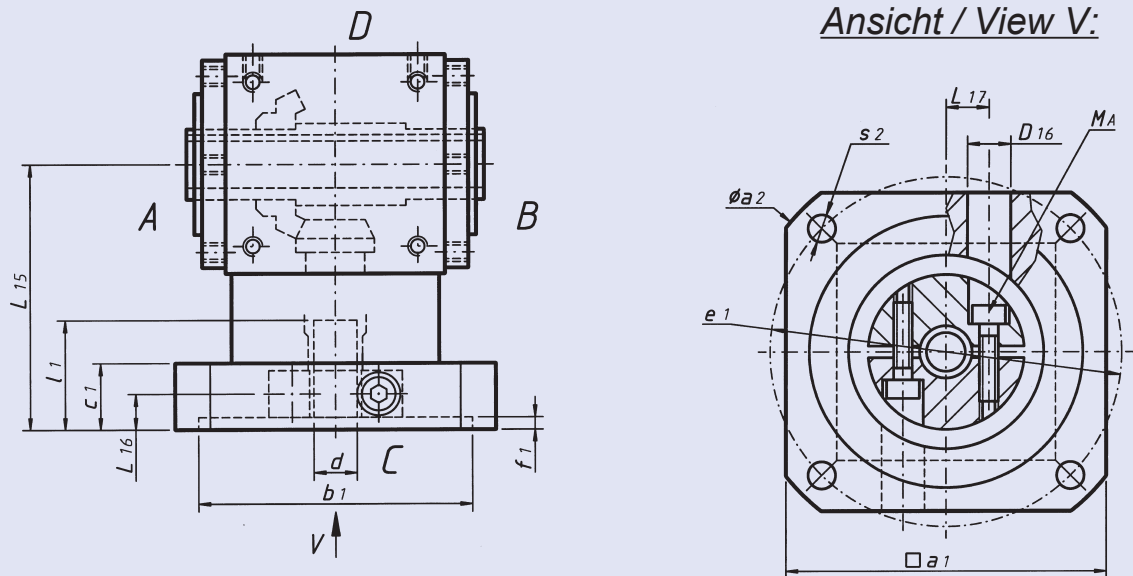

Abmessungen Typ H / MH 50

Dimensions Type H / MH 50

Typ / Type H

Grösse Size	Übersetzung Ratio	D1	D2	D3	D7	D11	D12	D13	D21	D22	D23	D25	D31	D32	D33
50	1 - 2	12 _{J6}	12 ^{H7}	12 ^{H7}	M6	44 _{F7}	64,5	54	44 _{F7}	64,5	54	20	44 _{F7}	64,5	54
	3 + 4														

Grösse Size	Übersetzung Ratio	L	L1	L7	L10	L12	L14	L20	L22	L24
50	1 - 2	92	26	65	100	42	2	46	42	2
	3 + 4				115					

Grösse Size	Übersetzung Ratio	L30	L32	L34	L71	R	Passfeder D1 Keyway D1	Passfeder D2 + D3 Keyway D2 + D3
50	1 - 2	46	42	2	45	0,8	4 x 4 x 20	b = 4 ^{JS9}
	3 + 4							

Typ / Type MH

Grösse Size	Übersetzung Ratio	d G7	l1	b1	e1	a1	a2	s2
50	1 - 4	9	23	70	85	75	100	4 x Ø 7 / M6
		11	26	80	100	90	120	4 x Ø 7 / M6
		14	33	95	115	115	140	4 x Ø 9 / M8

Grösse Size	Übersetzung Ratio	f1	c1	D16	L15	L16	L17
50	1 - 4	4,5	16	8,5	90	9,5	10

Bauarten Typ / Design Type H

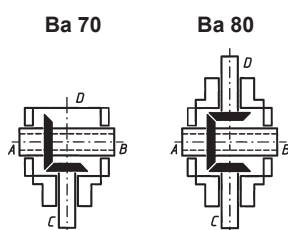

Bauarten Typ / Design Type MH

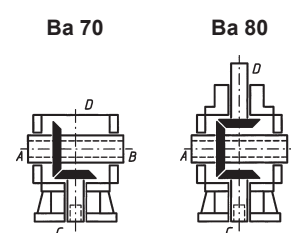

Typ / Type H

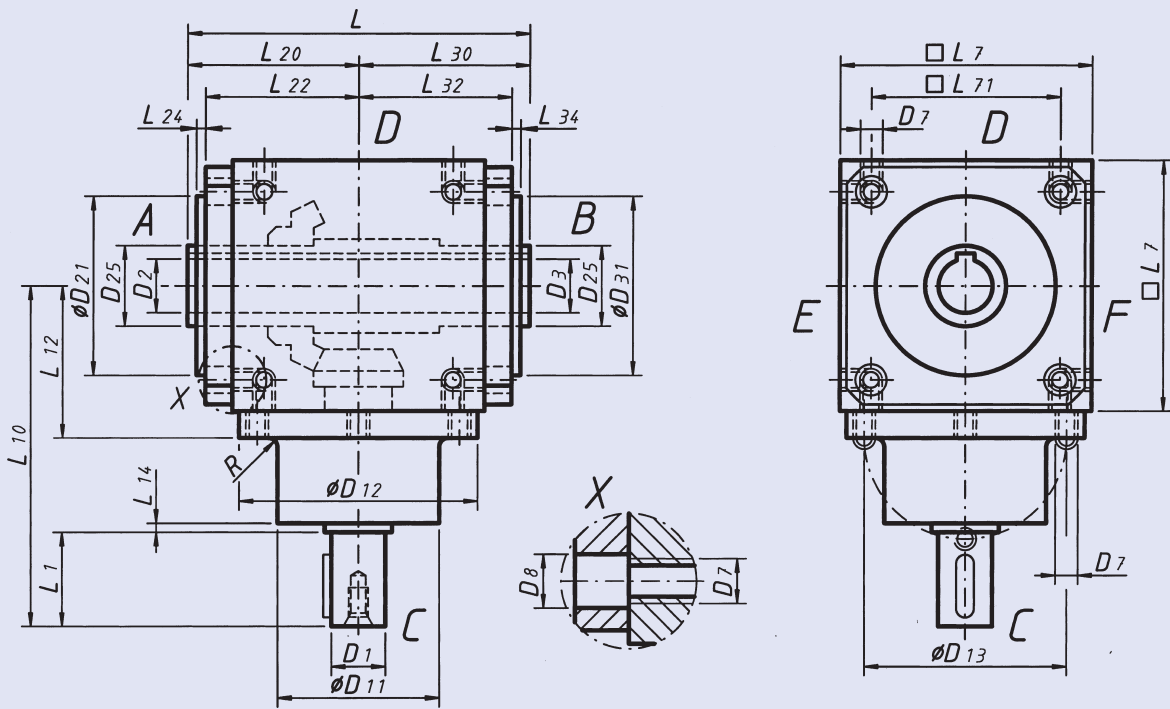

Typ / Type MH

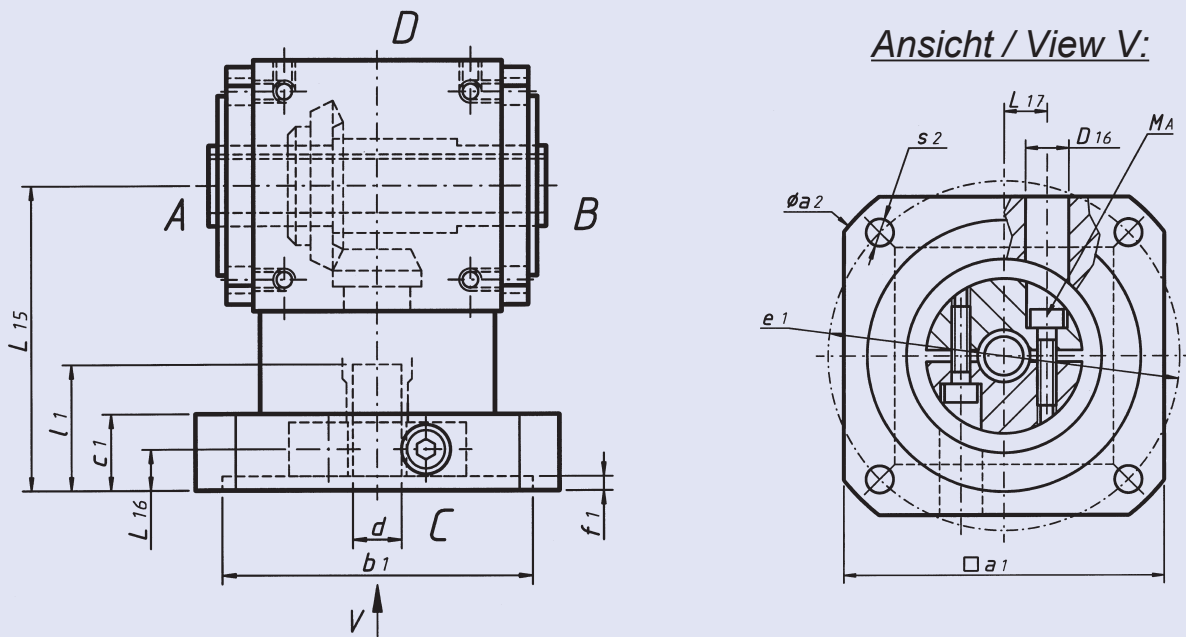

Typ / Type H

Grösse Size	Übersetzung Ratio	D1	D2	D3	D7	D8	D11	D12	D13	D21	D25	D31	L	L1	L7
100	1 - 2	18 _{j6}	18 ^{H7}	18 ^{H7}	M8	9	60 _{f7}	89 _{f7}	75	60 _{f7}	30	60 _{f7}	124	35	90
	3 + 4	15 _{j6}												30	
	5 + 6	12 _{j6}												25	
200	1 - 2	25 _{j6}	25 ^{H7}	25 ^{H7}	M10	11	80 _{f7}	119 _{f7}	100	80 _{f7}	40	80 _{f7}	170	45	120
	3 + 4	20 _{j6}												40	
	5 + 6	15 _{j6}												30	

Grösse Size	Übersetzung Ratio	L10	L12	L14	L20	L22	L24	L30	L32	L34	L71	R	Passfeder D1 Keyway D1	Passfeder D2+D3 Keyway D2+D3
100	1 - 2	122	55	2	62	55	3	62	55	3	70	1	6 x 6 x 25	b = 6 ^{JS9}
	3 + 4	127											5 x 5 x 20	
	5 + 6	122											4 x 4 x 16	
200	1 - 2	162	75	2	85	77	5	85	77	5	100	1	8 x 7 x 36	b = 8 ^{JS9}
	3 + 4	157											6 x 6 x 30	
	5 + 6	147											5 x 5 x 20	

Typ / Type MH

Grösse Size	Übersetzung Ratio	d G7	l1	b1	e1	a1	a2	s2
100	1 - 6	9	23	70	85	95	105	4 x Ø 7 / M6
		11	26	80	100	95	120	4 x Ø 7 / M6
		14	35	95	115	115	140	4 x Ø 9 / M8
		19	45	110	130	130	160	4 x Ø 9 / M8
200	1 - 6	11	26	80	100	125	140	4 x Ø 7 / M6
		14	35	95	115	125	140	4 x Ø 9 / M8
		19	45	110	130	130	160	4 x Ø 9 / M8
		24	55	110	130	140	160	4 x Ø 9 / M8
		28	65	130	165	140	190	4 x Ø 11 / M10

Grösse Size	Übersetzung Ratio	f1	c1	D16	L15	L16	L17
100	1 - 6	5	22	10	125	13	12,5
200	1 - 6	5	25	14	145	15	16,5

Bauarten Typ / Design Type H

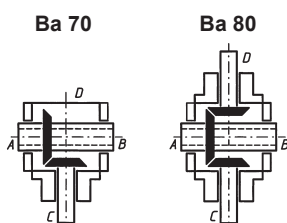

Bauarten Typ / Design Type MH

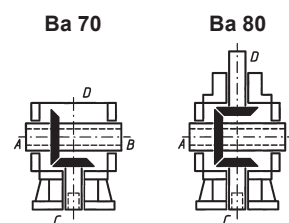

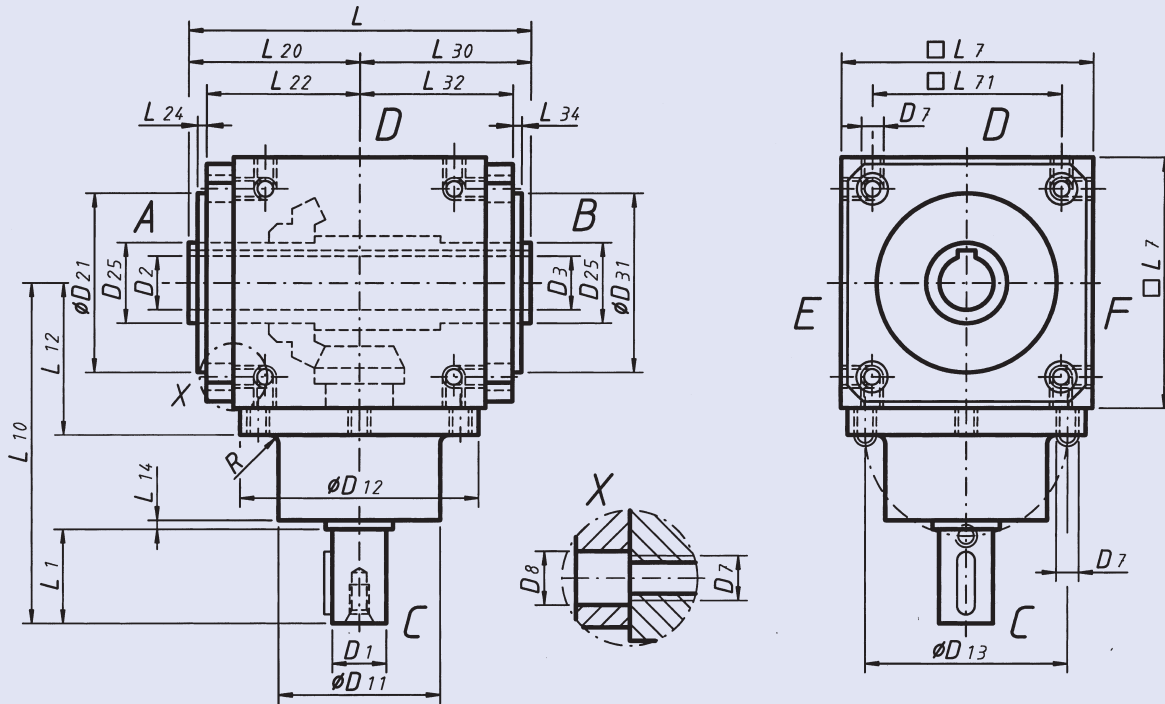

Bauarten / Design

Ba 70

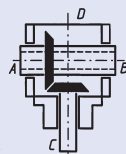

Ba 80

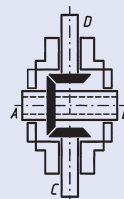

Abmessungen Typ H 230 - 400

Dimensions Type H 230 - 400

Grösse Size	Übersetzung Ratio	D1	D2	D3	D7	D8	D11	D12	D13	D21	D25	D31	L	L1
230	1 - 2	32 _{j6}	32 ^{H7}	32 ^{H7}	M10	11	95 _{f7}	135 _{f7}	115	100 _{f7}	45	100 _{f7}	174	50
	3 + 4	28 _{j6}												
	5 + 6	24 _{j6}												
250	1 - 2	35 _{j6}	35 ^{H7}	35 ^{H7}	M12	13,5	110 _{f7}	156 _{f7}	135	110 _{f7}	50	110 _{f7}	206	60
	3 + 4	28 _{j6}												55
	5 + 6	24 _{j6}												50
300	1 - 2	42 _{j6}	42 ^{H7}	42 ^{H7}	M12	13,5	120 _{f7}	198 _{f7}	175	120 _{f7}	60	120 _{f7}	250	80
	3 + 4	35 _{j6}												68
	5 + 6	28 _{j6}												55
370	1 - 2	55 _{j6}	55 ^{H7}	55 ^{H7}	M16	17,5	150 _{f7}	225 _{f7}	200	150 _{f7}	80	150 _{f7}	300	90
	3 + 4	40 _{j6}					140 _{f7}							80
	5 + 6	35 _{j6}												70
400	1 - 2	60 _{j6}	60 ^{H7}	60 ^{H7}	M16	17,5	160 _{f7}	258 _{f7}	230	180 _{f7}	85	180 _{f7}	350	110
	3 + 4	50 _{j6}												90
	5 + 6	45 _{j6}												

Grösse Size	Übersetzung Ratio	L7	L10	L12	L14	L20	L22	L24	L30	L32	L34	L71	R	Passfeder D1 Keyway D1	Passfeder D2+D3 Keyway D2+D3
230	1 - 2	140	180	83	2	87	82	3	87	82	3	110	2	10 x 8 x 45	b = 10 ^{JS9}
	3 + 4		195											8 x 7 x 40	
	5 + 6													8 x 7 x 40	
250	1 - 2	160	212	95	2	103	95	5	103	95	5	120	2	10 x 8 x 45	b = 10 ^{JS9}
	3 + 4		227											8 x 7 x 45	
	5 + 6		222											8 x 7 x 40	
300	1 - 2	200	273	120	3	125	117	6	125	117	6	160	3	12 x 8 x 60	b = 12 ^{JS9}
	3 + 4		261		2									10 x 8 x 45	
	5 + 6		248											8 x 7 x 45	
370	1 - 2	230	305	135	2	150	140	7	150	140	7	180	5	16 x 10 x 80	b = 16 ^{JS9}
	3 + 4		310											12 x 8 x 60	
	5 + 6		300											10 x 8 x 50	
400	1 - 2	260	380	150	5	175	150	22	175	150	22	220	5	18 x 11 x 90	b = 18 ^{JS9}
	3 + 4		360											14 x 9 x 70	
	5 + 6		360											14 x 9 x 70	

Abmessungen Typ H 230 - 400

Dimensions Type H 230 - 400

Grösse Size	Übersetzung Ratio	D1	D2	D3	D7	D8	D11	D12	D13	D21	D25	D31	L	L1
230	1 - 2	32 _{j6}	32 ^{H7}	32 ^{H7}	M10	11	95 _{f7}	135 _{f7}	115	100 _{f7}	45	100 _{f7}	174	50
	3 + 4	28 _{j6}												
	5 + 6	24 _{j6}												
250	1 - 2	35 _{j6}	35 ^{H7}	35 ^{H7}	M12	13,5	110 _{f7}	156 _{f7}	135	110 _{f7}	50	110 _{f7}	206	60
	3 + 4	28 _{j6}												55
	5 + 6	24 _{j6}												50
300	1 - 2	42 _{j6}	42 ^{H7}	42 ^{H7}	M12	13,5	120 _{f7}	198 _{f7}	175	120 _{f7}	60	120 _{f7}	250	80
	3 + 4	35 _{j6}												68
	5 + 6	28 _{j6}												55
370	1 - 2	55 _{j6}	55 ^{H7}	55 ^{H7}	M16	17,5	150 _{f7}	225 _{f7}	200	150 _{f7}	80	150 _{f7}	300	90
	3 + 4	40 _{j6}					140 _{f7}							80
	5 + 6	35 _{j6}												70
400	1 - 2	60 _{j6}	60 ^{H7}	60 ^{H7}	M16	17,5	160 _{f7}	258 _{f7}	230	180 _{f7}	85	180 _{f7}	350	110
	3 + 4	50 _{j6}												90
	5 + 6	45 _{j6}												

Grösse Size	Übersetzung Ratio	L7	L10	L12	L14	L20	L22	L24	L30	L32	L34	L71	R	Passfeder D1 Keyway D1	Passfeder D2+D3 Keyway D2+D3
230	1 - 2	140	180	83	2	87	82	3	87	82	3	110	2	10 x 8 x 45	b = 10 ^{JS9}
	3 + 4		195											8 x 7 x 40	
	5 + 6													8 x 7 x 40	
250	1 - 2	160	212	95	2	103	95	5	103	95	5	120	2	10 x 8 x 45	b = 10 ^{JS9}
	3 + 4		227											8 x 7 x 45	
	5 + 6		222											8 x 7 x 40	
300	1 - 2	200	273	120	3	125	117	6	125	117	6	160	3	12 x 8 x 60	b = 12 ^{JS9}
	3 + 4		261		2									10 x 8 x 45	
	5 + 6		248											8 x 7 x 45	
370	1 - 2	230	305	135	2	150	140	7	150	140	7	180	5	16 x 10 x 80	b = 16 ^{JS9}
	3 + 4		310											12 x 8 x 60	
	5 + 6		300											10 x 8 x 50	
400	1 - 2	260	380	150	5	175	150	22	175	150	22	220	5	18 x 11 x 90	b = 18 ^{JS9}
	3 + 4		360											14 x 9 x 70	
	5 + 6		360											14 x 9 x 70	

Ansicht / View V:

Vierkant-Flansch / Square flange

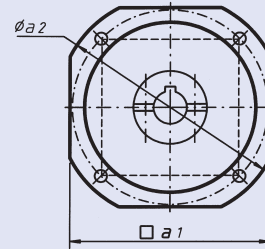

Bohrbild bei 4 Anschraublöchern
4-hole arrangement

Runder Flansch / Round flange

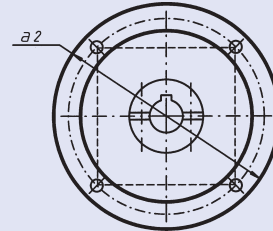

Bohrbild bei 4 Anschraublöchern
4-hole arrangement

Runder Flansch / Round flange

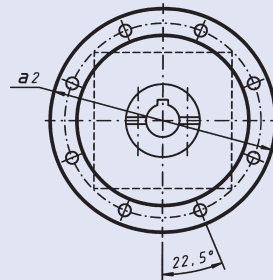

Bohrbild bei 8 Anschraublöchern
8-hole arrangement

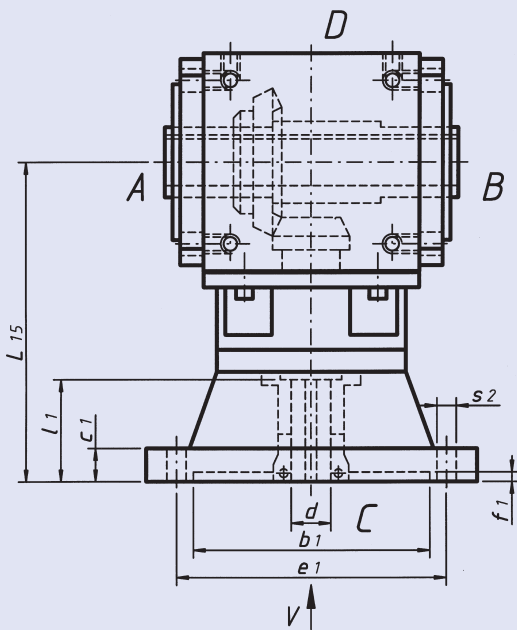

Bauarten / Design

Ba 70

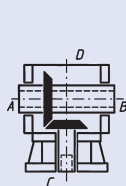

Ba 80

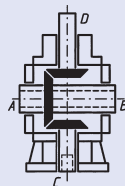

Typ / Type H

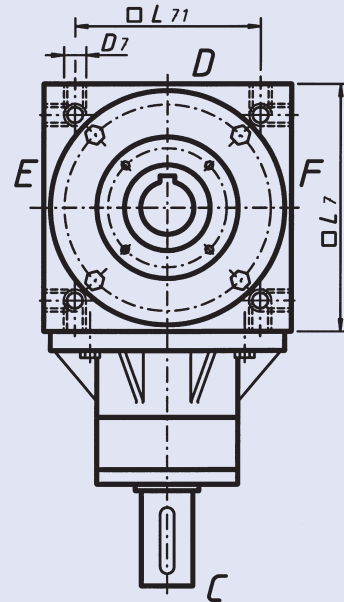
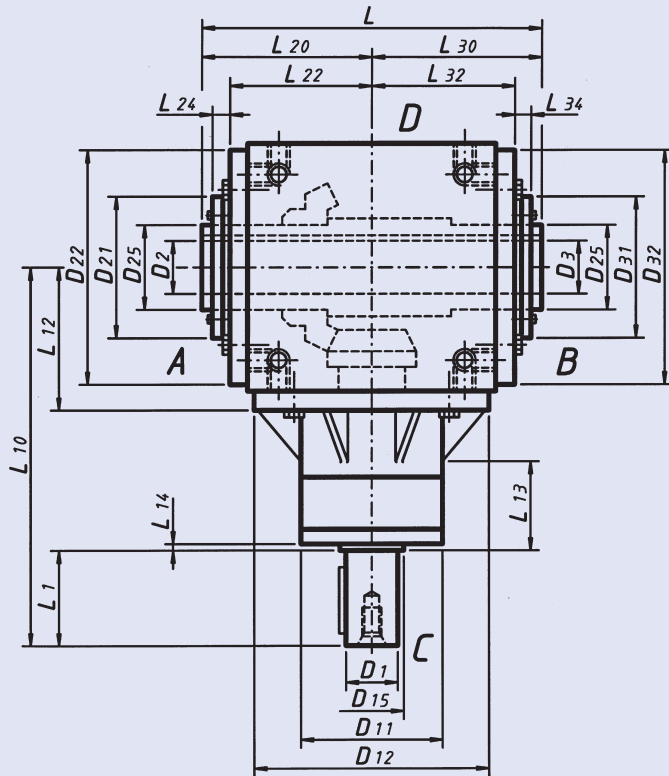

Typ / Type MH

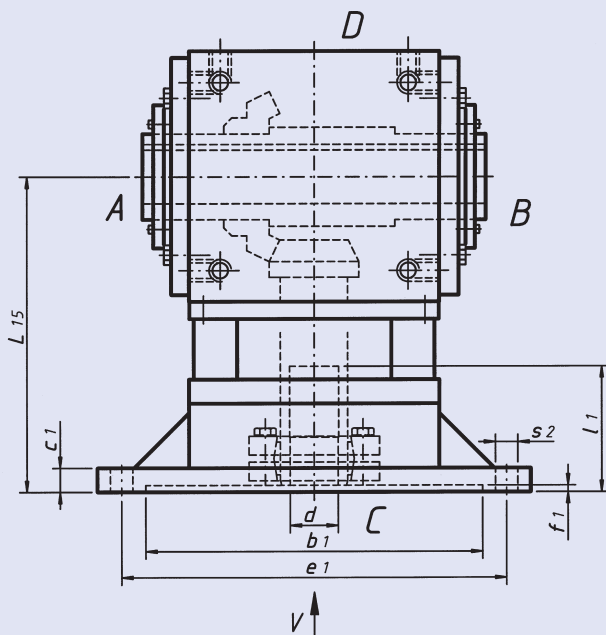

Ansicht / View V:

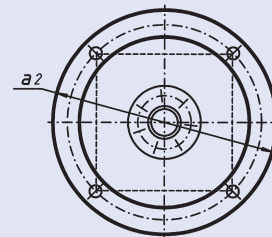

Bohrbild bei 4 Anschraublochern
4-hole arrangement

Ansicht / View V:

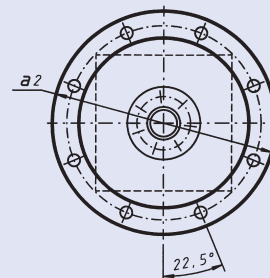

Bohrbild bei 8 Anschraublochern
(ab Motorbaugröße 225)
8-hole arrangement
(from motor size 225)

Typ / Type H

Grösse Size	Übersetzung Ratio	D1	D2	D3	D7	D11	D12	D15	D21	D22	D25	D31	D32
500	1 - 2	80 _{j6}	80 ^{H7}	80 ^{H7}	M20	250	345 _{f7}	85	200	345 _{f7}	105	200	345 _{f7}
	3 + 4	65 _{j6}						70					
	5 + 6	55 _{j6}											

Grösse Size	Übersetzung Ratio	L	L1	L7	L10	L12	L13	L14	L20	L22	L24
500	1 - 2	480	170	350	570	202	90	5	240	200	25
	3 + 4		140		540						
	5 + 6		110		510						

Grösse Size	Übersetzung Ratio	L30	L32	L34	L71	Passfeder D1 Keyway D1	Passfeder D2 + D3 Keyway D2 + D3
500	1 - 2	240	202	23	285	22 x 14 x 160	b = 22 ^{JS9}
	3 + 4					18 x 11 x 125	
	5 + 6					16 x 10 x 90	

Typ / Type MH

Grösse Size	Übersetzung Ratio	d G7	l1	b1	e1	a2	s2	f1	c1	L15
500	1 - 4	42	115	250	300	350	4 x M16	7	25	440
		55	115	300	350	400	4 x M16			
		60	145	350	400	450	8 x M16			
	4,5 - 6	65	145	450	500	550	8 x M16	415		

Bauarten Typ / Design Type H

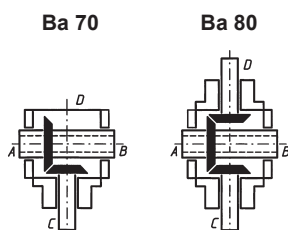

Bauarten Typ / Design Type MH

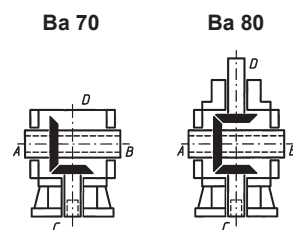

Typ / Type H

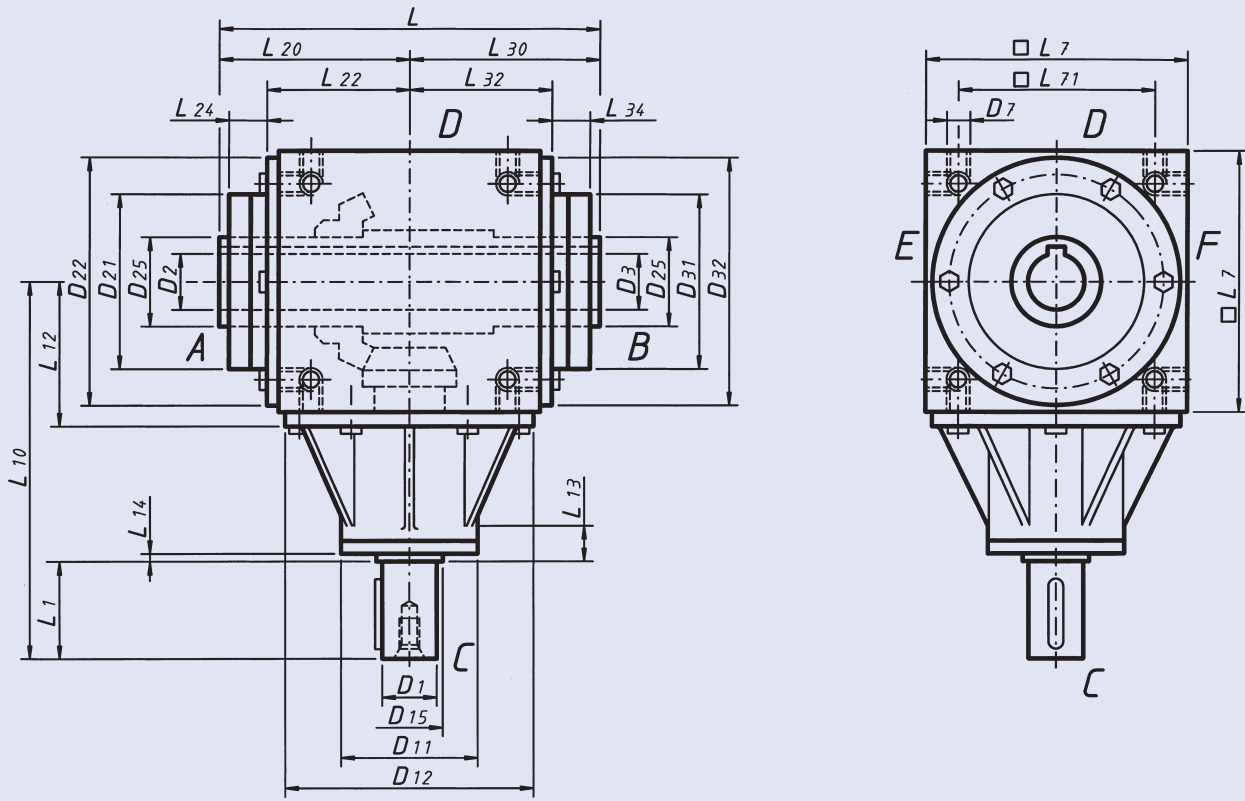

Typ / Type MH

Auf Anfrage
On request

Abmessungen Typ H / MH 600

Dimensions Type H / MH 600

Grösse Size	Übersetzung Ratio	D1	D2	D3	D7	D11	D12	D15	D21	D22	D25	D31	D32
600	1 - 2	90 _{j6}	100 ^{H7}	100 ^{H7}	M20	190	445 _{f7}	95	300	445 _{f7}	145	300	445 _{f7}
	3 + 4	75 _{j6}											
	5 + 6	60 _{j6}						75					

Grösse Size	Übersetzung Ratio	L	L1	L7	L10	L12	L13	L14	L20	L22	L24
600	1 - 2	640	150	450	600	250	33	5	320	245	70
	3 + 4		120		570						
	5 + 6		110		530						

Grösse Size	Übersetzung Ratio	L30	L32	L34	L71	Passfeder D1 Keyway D1	Passfeder D2 + D3 Keyway D2 + D3
600	1 - 2	320	245	70	360	25 x 14 x 140	b = 28 ^{JS9}
	3 + 4					20 x 12 x 110	
	5 + 6					18 x 11 x 100	

Bauarten / Design

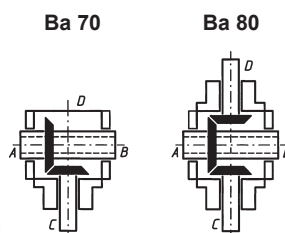

Typ / Type K

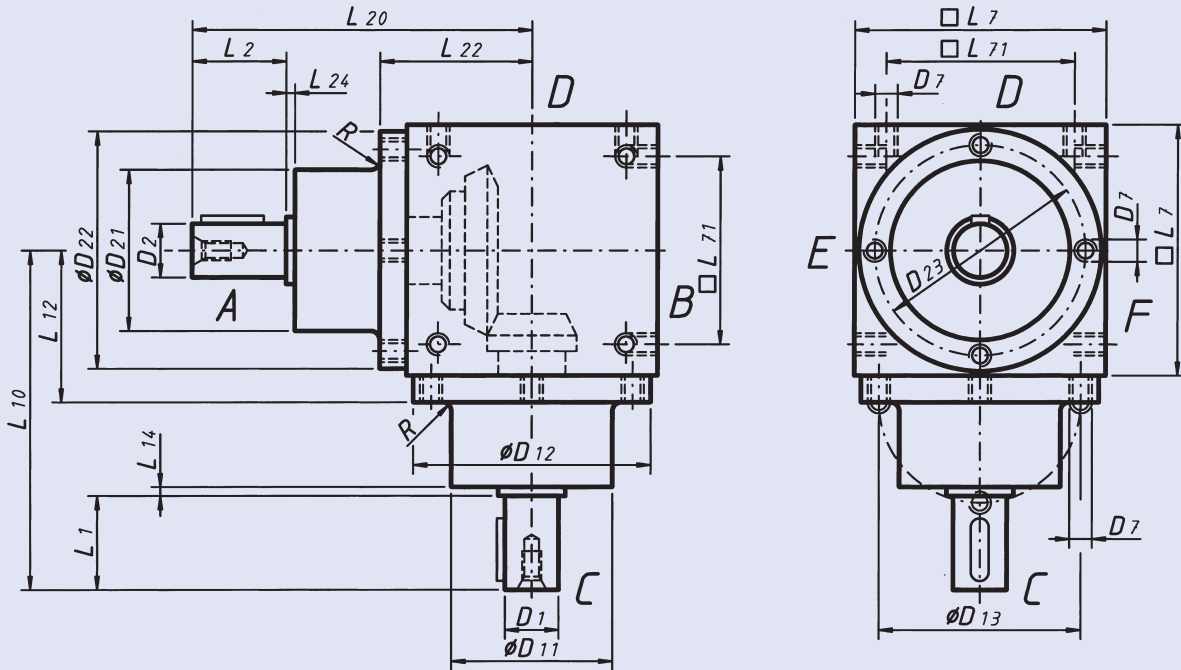

Typ / Type MK

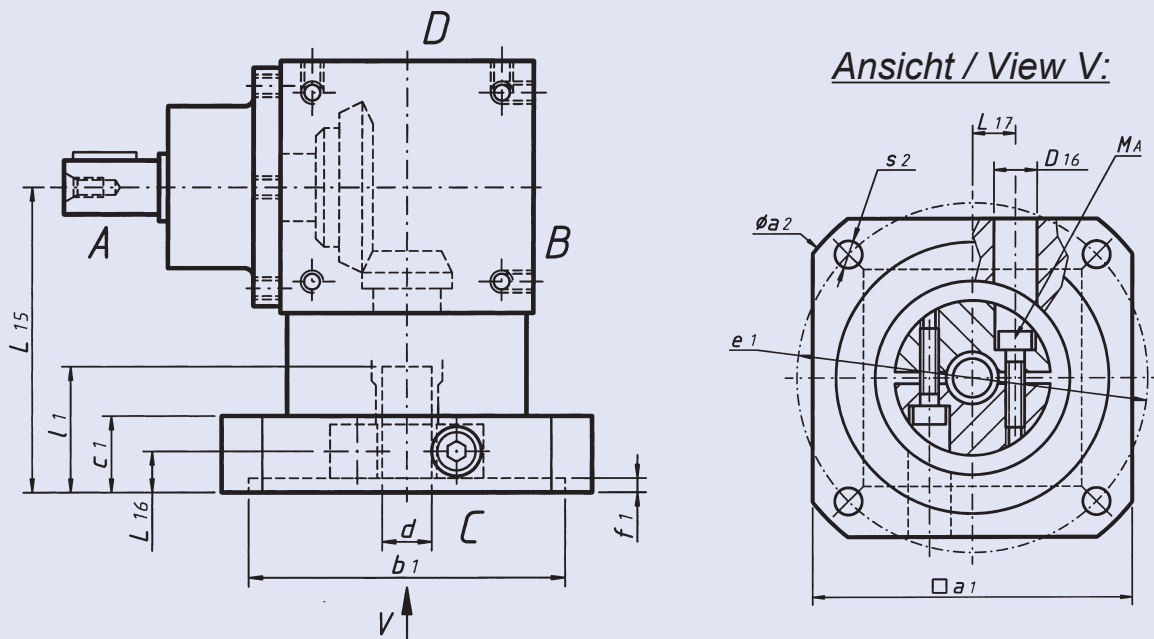

Typ / Type K

Grösse Size	Übersetzung Ratio	D1	D2	D7	D11	D12	D13	D21	D22	D23
50	1 - 2	12 _{j6}	12 _{j6}	M6	44 _{f7}	64,5	54	44 _{f7}	64,5	54
	3 + 4									

Grösse Size	Übersetzung Ratio	L1	L2	L7	L10	L12	L14	L20	L22	L24
50	1 - 2	26	26	65	100	42	2	100	42	2
	3 + 4				115					

Grösse Size	Übersetzung Ratio	L71	R	Passfeder D1 Keyway D1	Passfeder D2 + D3 Keyway D2 + D3
50	1 - 2	45	0,8	4 x 4 x 20	4 x 4 x 20
	3 + 4				

Typ / Type MK

Grösse Size	Übersetzung Ratio	d G7	l1	b1	e1	a1	a2	s2
50	1 - 4	9	23	70	85	75	100	4 x Ø 7 / M6
		11	26	80	100	90	120	4 x Ø 7 / M6
		14	33	95	115	115	140	4 x Ø 9 / M8

Grösse Size	Übersetzung Ratio	f1	c1	D16	L15	L16	L17
50	1 - 4	4,5	16	8,5	90	9,5	10

Bauarten Typ / Design Type K

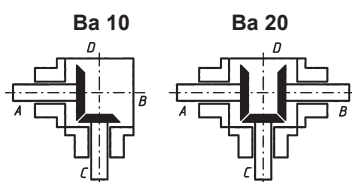

Bauarten Typ / Design Type MK

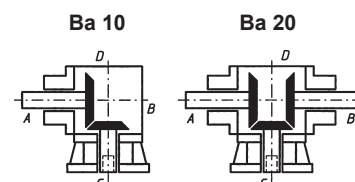

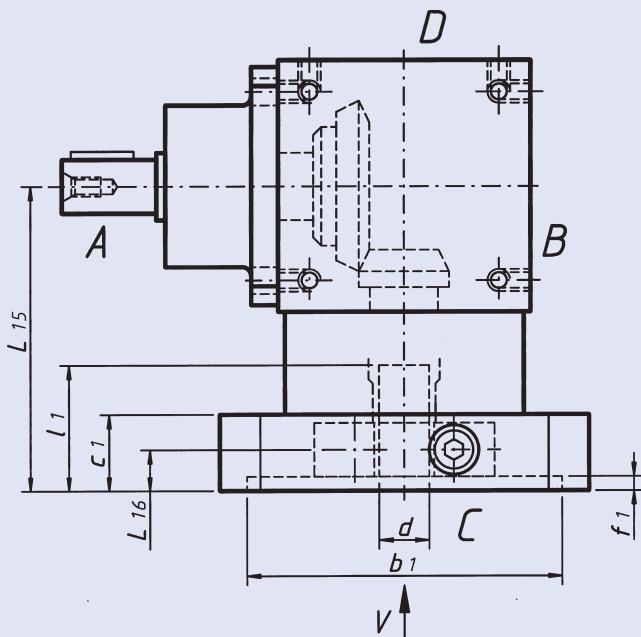
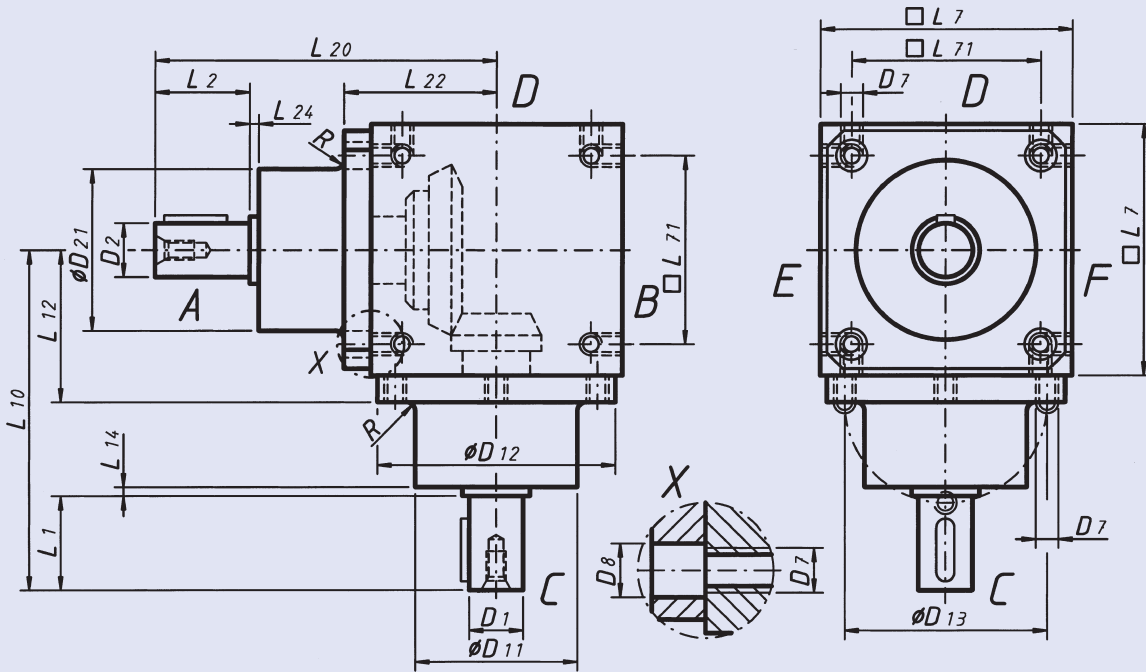

Ansicht / View V:

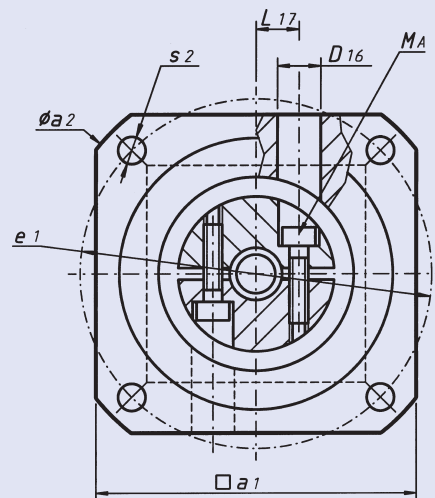

Typ / Type K

Grösse Size	Übersetzung Ratio	D1	D2	D7	D8	D11	D12	D13	D21
100	1 - 2	18 _{j6}	18 _{j6}	M8	9	60 _{f7}	89 _{f7}	75	60 _{f7}
	3 + 4	15 _{j6}							
	5 + 6	12 _{j6}							
200	1 - 2	25 _{j6}	25 _{j6}	M10	11	80 _{f7}	119 _{f7}	100	80 _{f7}
	3 + 4	20 _{j6}							
	5 + 6	15 _{j6}							

Grösse Size	Übersetzung Ratio	L1	L2	L7	L10	L12	L14	L20	L22	L24	L71	R	Passfeder D1 Keyway D1	Passfeder D2 Keyway D2
100	1 - 2	35	35	90	122	55	2	122	55	2	70	1	6 x 6 x 25	6 x 6 x 25
	3 + 4	30			127								5 x 5 x 20	
	5 + 6	25			122								4 x 4 x 16	
200	1 - 2	45	45	120	162	75	2	162	75	2	100	1	8 x 7 x 36	8 x 7 x 36
	3 + 4	40			157								6 x 6 x 30	
	5 + 6	30			147								5 x 5 x 20	

Typ / Type MK

Grösse Size	Übersetzung Ratio	d G7	l1	b1	e1	a1	a2	s2
100	1 - 6	9	23	70	85	95	105	4 x Ø 7 / M6
		11	26	80	100	95	120	4 x Ø 7 / M6
		14	35	95	115	115	140	4 x Ø 9 / M8
		19	45	110	130	130	160	4 x Ø 9 / M8
200	1 - 6	11	26	80	100	125	140	4 x Ø 7 / M6
		14	35	95	115	125	140	4 x Ø 9 / M8
		19	45	110	130	130	160	4 x Ø 9 / M8
		24	55	110	130	140	160	4 x Ø 9 / M8
		28	65	130	165	140	190	4 x Ø 11 / M10

Grösse Size	Übersetzung Ratio	f1	c1	D16	L15	L16	L17
100	1 - 6	5	22	10	125	13	12,5
200	1 - 6	5	25	14	145	15	16,5

Bauarten Typ / Design Type K

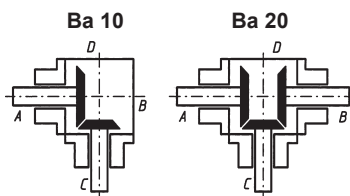

Bauarten Typ / Design Type MK

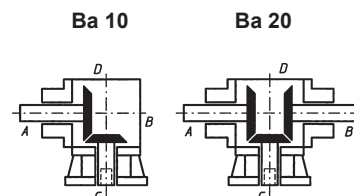

Typ / Type K

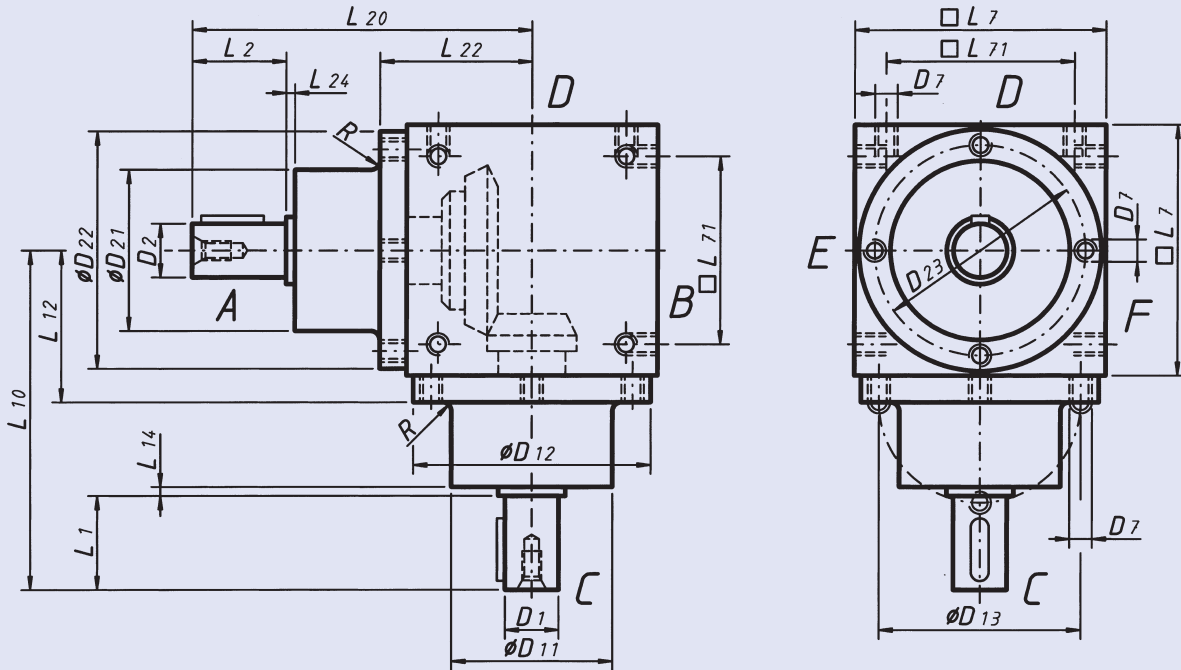

Typ / Type MK

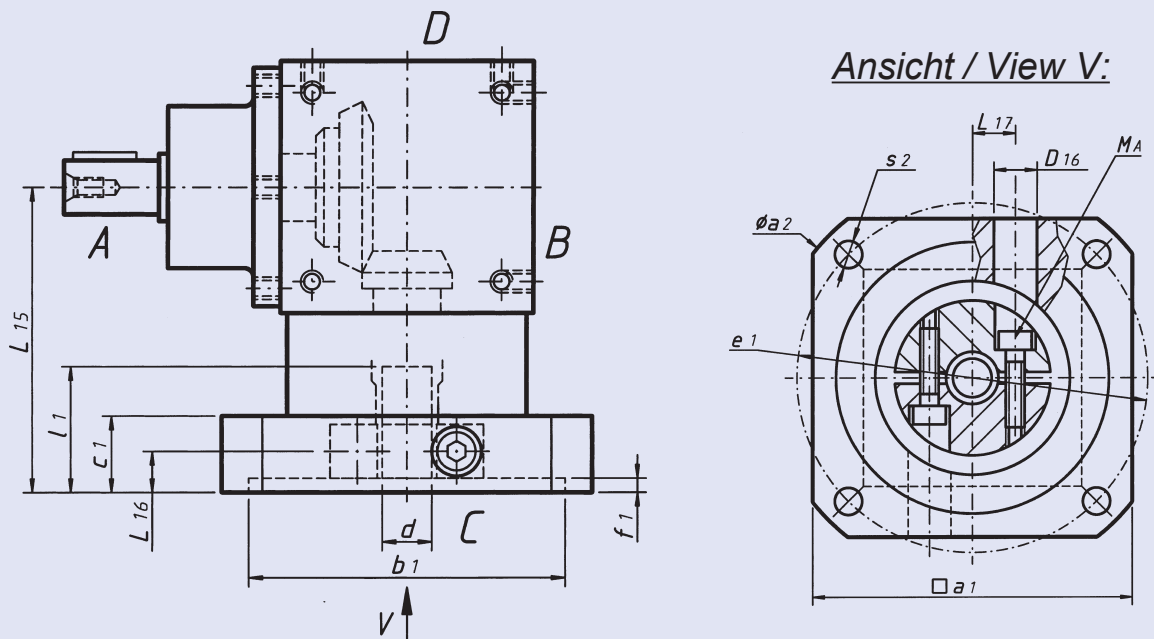

Typ / Type K

Grösse Size	Übersetzung Ratio	D1	D2	D7	D11	D12	D13	D21	D22	D23
50	1 - 2	12 _{j6}	12 _{j6}	M6	44 _{f7}	64,5	54	44 _{f7}	64,5	54
	3 + 4									

Grösse Size	Übersetzung Ratio	L1	L2	L7	L10	L12	L14	L20	L22	L24
50	1 - 2	26	26	65	100	42	2	100	42	2
	3 + 4				115					

Grösse Size	Übersetzung Ratio	L71	R	Passfeder D1 Keyway D1	Passfeder D2 + D3 Keyway D2 + D3
50	1 - 2	45	0,8	4 x 4 x 20	4 x 4 x 20
	3 + 4				

Typ / Type MK

Grösse Size	Übersetzung Ratio	d G7	l1	b1	e1	a1	a2	s2
50	1 - 4	9	23	70	85	75	100	4 x Ø 7 / M6
		11	26	80	100	90	120	4 x Ø 7 / M6
		14	33	95	115	115	140	4 x Ø 9 / M8

Grösse Size	Übersetzung Ratio	f1	c1	D16	L15	L16	L17
50	1 - 4	4,5	16	8,5	90	9,5	10

Bauarten Typ / Design Type K

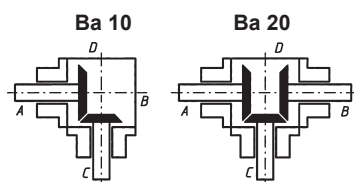

Bauarten Typ / Design Type MK

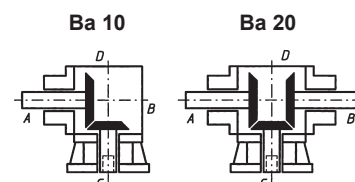

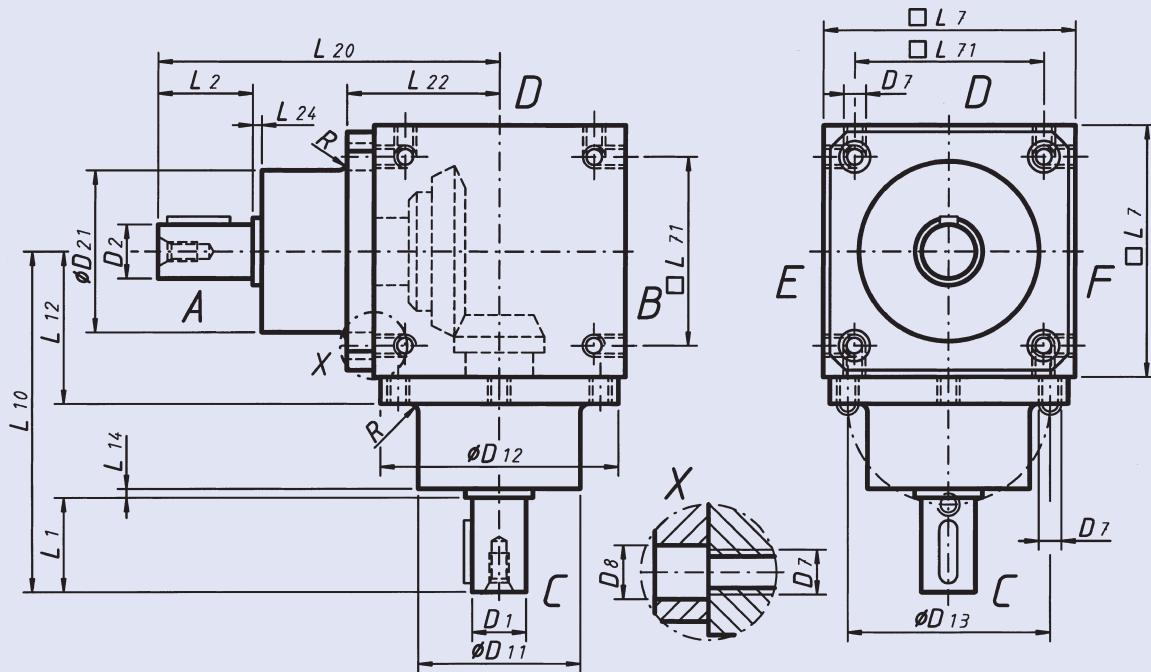

Bauarten / Design

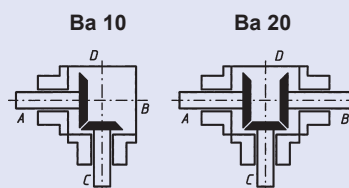

Abmessungen Typ K 230 - 400
Dimensions Type K 230 - 400

Grösse Size	Übersetzung Ratio	D1	D2	D7	D8	D11	D12	D13	D21
230	1 - 2	32 _{j6}	32 _{j6}	M10	11	95 _{f7}	135 _{f7}	115	95 _{f7}
	3 + 4	28 _{j6}							
	5 + 6	24 _{j6}							
250	1 - 2	35 _{j6}	35 _{j6}	M12	13,5	110 _{f7}	156 _{f7}	135	110 _{f7}
	3 + 4	28 _{j6}							
	5 + 6	24 _{j6}							
300	1 - 2	42 _{j6}	42 _{j6}	M12	13,5	120 _{f7}	198 _{f7}	175	120 _{f7}
	3 + 4	35 _{j6}							
	5 + 6	28 _{j6}							
370	1 - 2	55 _{j6}	55 _{j6}	M16	17,5	150 _{f7}	225 _{f7}	200	150 _{f7}
	3 + 4	40 _{j6}				140 _{f7}			
	5 + 6	35 _{j6}							
400	1 - 2	60 _{j6}	60 _{j6}	M16	17,5	160 _{f7}	258 _{f7}	230	160 _{f7}
	3 + 4	50 _{j6}							
	5 + 6	45 _{j6}							

Grösse Size	Übersetzung Ratio	L1	L2	L7	L10	L12	L14	L20	L22	L24	L71	R	Passfeder D1 Keyway D1	Passfeder D2+D3 Keyway D2+D3
230	1 - 2	50	50	140	180	85	2	180	85	2	110	2	10 x 8 x 45	10 x 8 x 45
	3 + 4				195								8 x 7 x 40	
	5 + 6				195								8 x 7 x 40	
250	1 - 2	60	60	160	212	95	2	212	95	2	120	2	10 x 8 x 45	10 x 8 x 45
	3 + 4				227								8 x 7 x 45	
	5 + 6				222								8 x 7 x 40	
300	1 - 2	80	80	200	273	120	3	273	120	3	160	3	12 x 8 x 60	12 x 8 x 60
	3 + 4				261		2						10 x 8 x 45	
	5 + 6				248								8 x 7 x 45	
370	1 - 2	90	90	230	305	135	2	305	135	2	180	5	16 x 10 x 80	16 x 10 x 80
	3 + 4				310								12 x 8 x 60	
	5 + 6				300								10 x 8 x 50	
400	1 - 2	110	110	260	380	150	5	380	150	5	220	5	18 x 11 x 90	18 x 11 x 90
	3 + 4	90			360								14 x 9 x 70	
	5 + 6				360								14 x 9 x 70	

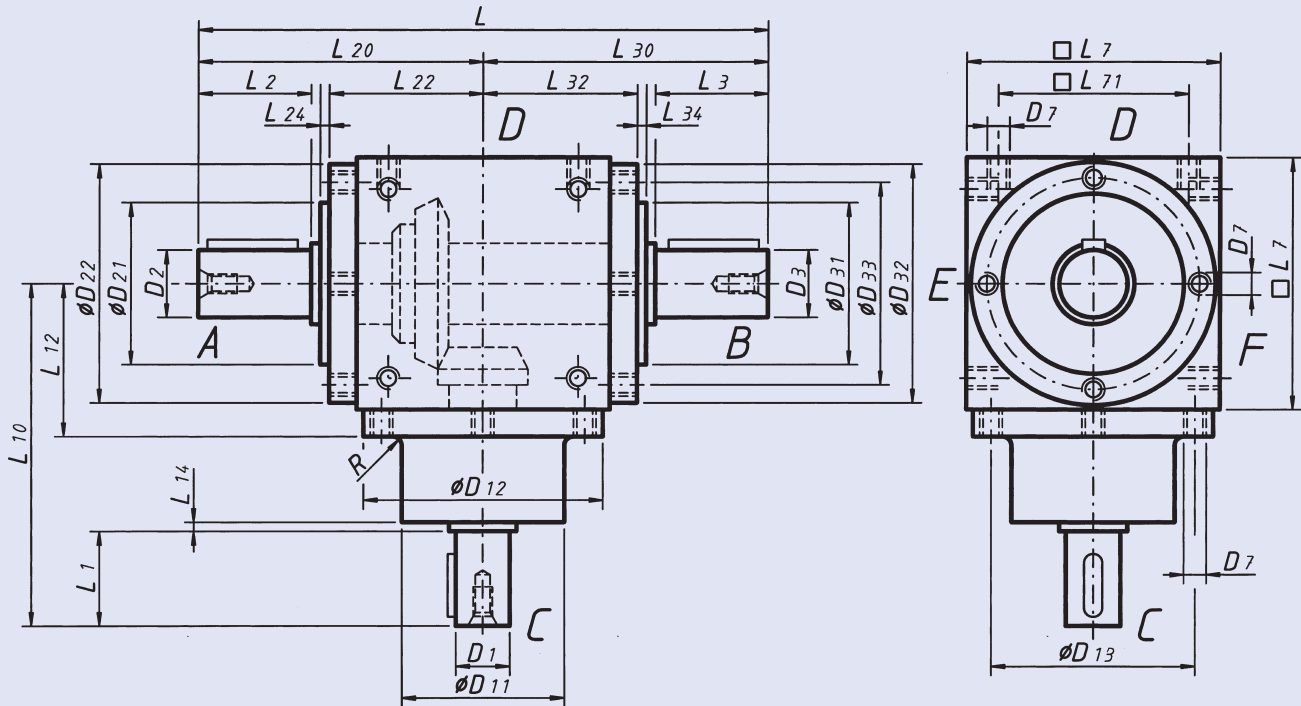

Bauarten / Design

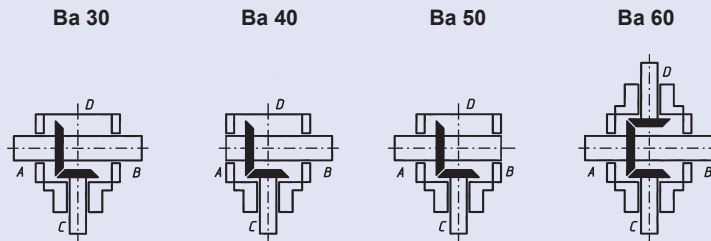

Hinweis:

Bei der Bauart 30 und 60 können über die durchgehende Welle (von A nach B) größere Drehmomente übertragen werden. (zul. Drehmoment 20 Nm). Die zul. Drehmomente der Kegelradsätze entsprechen dem Typ L.

Note:

The through shaft (A to B) on design 30 and 60 can transmit higher torques. (perm. torque 20 Nm). The permissible torque of the bevel gears is the same as type L.

Abmessungen Typ LV 50

Dimensions Type LV 50

Grösse Size	Übersetzung Ratio	D1	D2	D3	D7	D11	D12	D13	D21	D22	D23	D31	D32	D33
50	1 - 2	12 _{j6}	14 _{j6}	14 _{j6}	M6	44 _{f7}	64,5	54	44 _{f7}	64,5	54	44 _{f7}	64,5	54
	3 + 4													

Grösse Size	Übersetzung Ratio	L	L1	L2	L3	L7	L10	L12	L14	L20	L22	L24	L30	L32
50	1 - 2	152	26	30	30	65	100	42	2	76	42	2	76	42
	3 + 4						115							

Grösse Size	Übersetzung Ratio	L34	L71	R	Passfeder D1 Keyway D1	Passfeder D2 + D3 Keyway D2 + D3
50	1 - 2	2	45	0,8	4 x 4 x 20	5 x 5 x 25
	3 + 4					

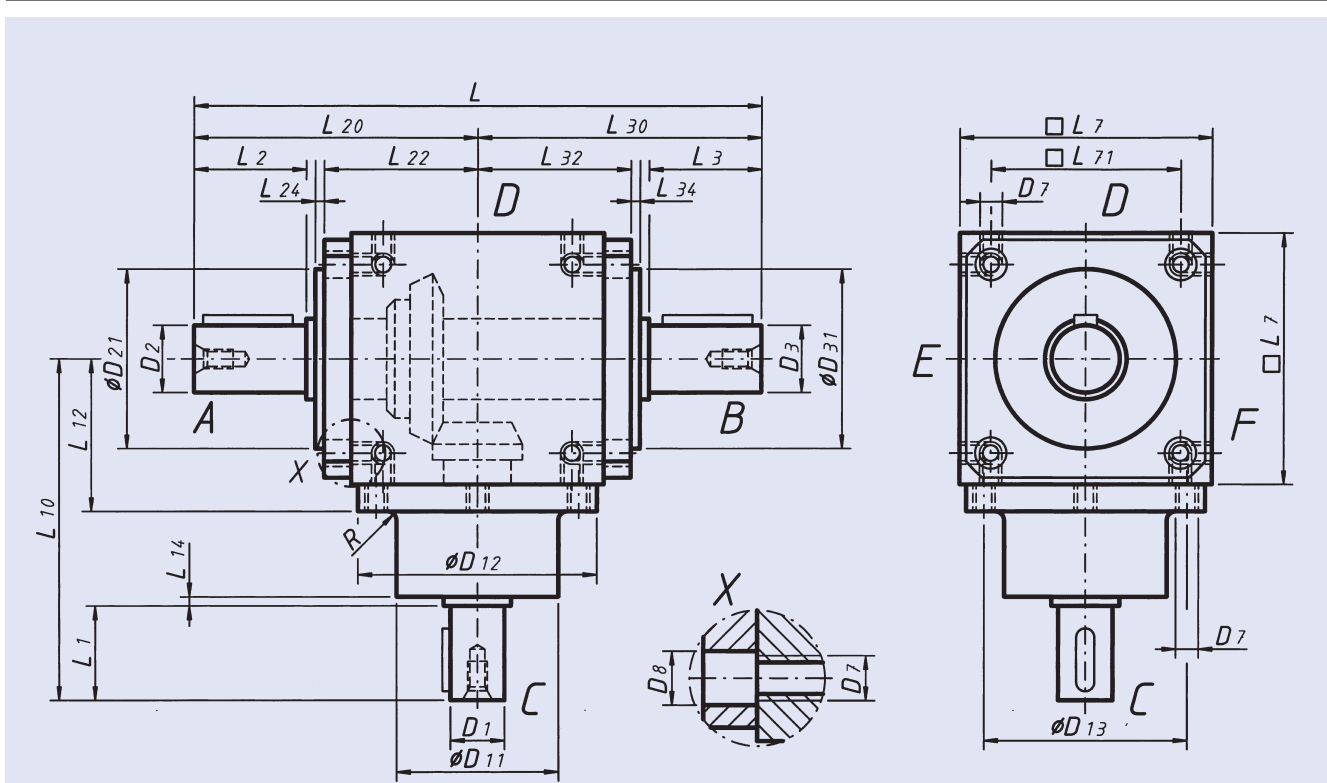

Bauarten / Design

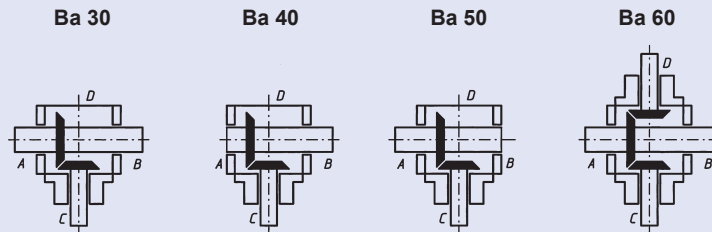

Hinweis:

Bei der Bauart 30 und 60 können über die durchgehende Welle (von A nach B) größere Drehmomente übertragen werden. (siehe nachfolgende Tabelle). Die zul. Drehmomente der Kegelradsätze entsprechen dem Typ L.

Note:

The through shaft (A to B) on design 30 and 60 can transmit higher torques. (see below table)
The permissible torque of the bevel gears is the same as type L.

Typ Type	zul. Drehmoment von A nach B perm. torque from A to B
LV 100	100 Nm
LV 200	250 Nm
LV 230	400 Nm
LV 250	600 Nm
LV 300	1300 Nm
LV 370	3200 Nm
LV 400	3500 Nm

Abmessungen Typ LV 100 - 400

Dimensions Type LV 100 - 400

Grösse Size	Übersetzung Ratio	D1	D2	D3	D7	D8	D11	D12	D13	D21	D31	L	L1	L2	L3
100	1 - 2	18 _{j6}	24 _{j6}	24 _{j6}	M8	9	60 _{f7}	89 _{f7}	75	60 _{f7}	60 _{f7}	210	35	45	45
	3 + 4	15 _{j6}											30		
	5 + 6	12 _{j6}											25		
200	1 - 2	25 _{j6}	32 _{j6}	32 _{j6}	M10	11	80 _{f7}	119 _{f7}	100	80 _{f7}	80 _{f7}	286	45	60	60
	3 + 4	20 _{j6}											40		
	5 + 6	15 _{j6}											30		
230	1 - 2	32 _{j6}	38 _{j6}	38 _{j6}	M10	11	95 _{f7}	135 _{f7}	115	100 _{f7}	100 _{f7}	314	50	70	70
	3 + 4	28 _{j6}											50		
	5 + 6	24 _{j6}													
250	1 - 2	35 _{j6}	42 _{j6}	42 _{j6}	M12	13,5	110 _{f7}	156 _{f7}	135	110 _{f7}	110 _{f7}	362	60	80	80
	3 + 4	28 _{j6}											55		
	5 + 6	24 _{j6}											50		
300	1 - 2	42 _{j6}	55 _{j6}	55 _{j6}	M12	13,5	120 _{f7}	198 _{f7}	175	120 _{f7}	120 _{f7}	448	80	100	100
	3 + 4	35 _{j6}											68		
	5 + 6	28 _{j6}											55		
370	1 - 2	55 _{j6}	70 _{j6}	70 _{j6}	M16	17,5	150 _{f7}	225 _{f7}	200	150 _{f7}	150 _{f7}	540	90	120	120
	3 + 4	40 _{j6}					140 _{f7}						80		
	5 + 6	35 _{j6}					70								
400	1 - 2	60 _{j6}	75 _{j6}	75 _{j6}	M16	17,5	160 _{f7}	258 _{f7}	230	180 _{f7}	180 _{f7}	634	110	140	140
	3 + 4	50 _{j6}											90		
	5 + 6	45 _{j6}													

Grösse Size	Übersetzung Ratio	L7	L10	L12	L14	L20	L22	L24	L30	L32	L34	L71	R	Passfeder D1 Keyway D1	Passfeder/Key- way D2,D3
100	1 - 2	90	122	55	2	105	55	4	105	55	4	70	1	6 x 6 x 25	8 x 7 x 36
	3 + 4		127											5 x 5 x 20	
	5 + 6		122											4 x 4 x 16	
200	1 - 2	120	162	75	2	143	77	5	143	77	5	100	1	8 x 7 x 36	10 x 8 x 45
	3 + 4		157											6 x 6 x 30	
	5 + 6		147											5 x 5 x 20	
230	1 - 2	140	180	83	2	157	82	3	157	82	3	110	2	10 x 8 x 45	10 x 8 x 60
	3 + 4		195											8 x 7 x 40	
	5 + 6													8 x 7 x 40	
250	1 - 2	160	212	95	2	181	95	5	181	95	5	120	2	10 x 8 x 45	12 x 8 x 60
	3 + 4		227											8 x 7 x 45	
	5 + 6		222											8 x 7 x 40	
300	1 - 2	200	273	120	3	224	117	6	224	117	6	160	3	12 x 8 x 60	16 x 10 x 80
	3 + 4		261		2									10 x 8 x 45	
	5 + 6		248											8 x 7 x 45	
370	1 - 2	230	305	135	2	270	140	7	270	140	7	180	5	16 x 10 x 80	20 x 12 x 100
	3 + 4		310											12 x 8 x 60	
	5 + 6		300											10 x 8 x 50	
400	1 - 2	260	380	150	5	317	150	22	317	150	22	220	5	18 x 11 x 90	20 x 12 x 100
	3 + 4		360										10	14 x 9 x 70	
	5 + 6		360											14 x 9 x 70	

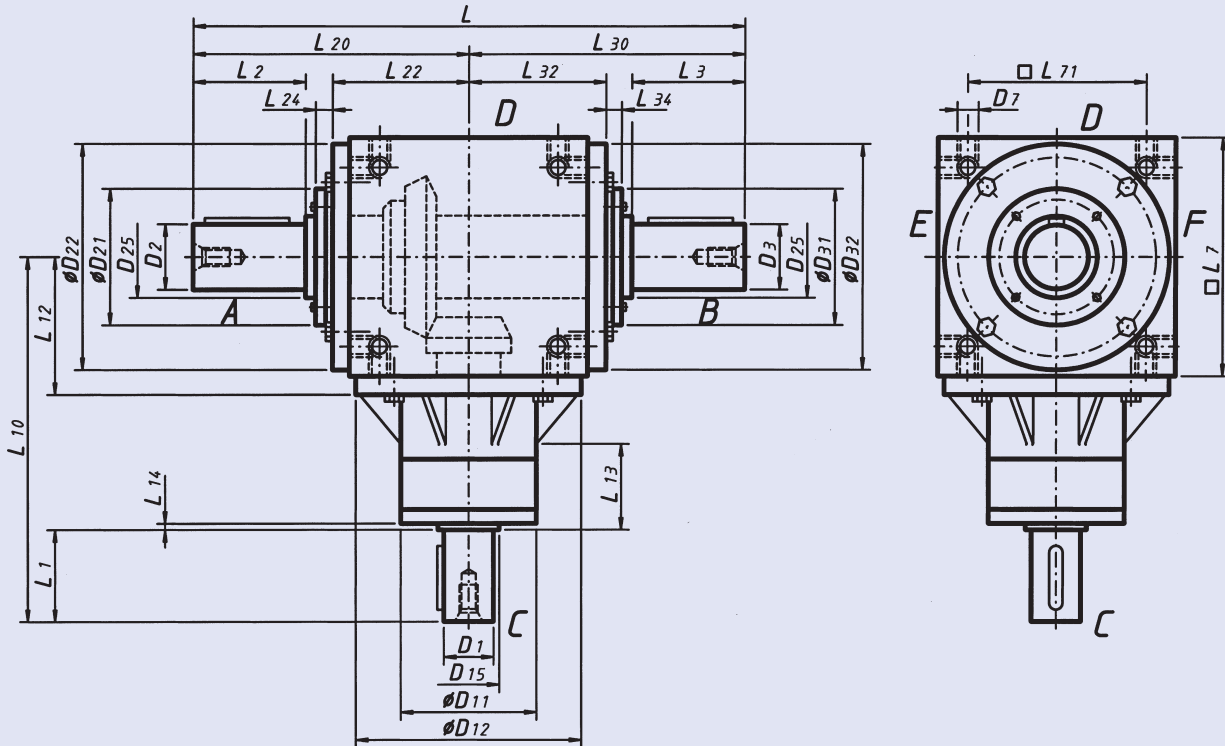

Bauarten / Design

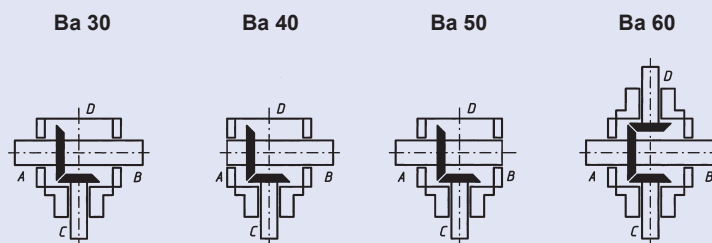

Hinweis:

Bei der Bauart 30 und 60 können über die durchgehende Welle (von A nach B) größere Drehmomente übertragen werden. (zul. Drehmoment 17 500 Nm). Die zul. Drehmomente der Kegelaradsätze entsprechen dem Typ L.

Note:

The through shaft (A to B) on design 30 and 60 can transmit higher torques. (perm. torque 17 500 Nm). The permissible torque of the bevel gears is the same as type L.

Abmessungen Typ LV 500
Dimensions Type LV 500

Grösse Size	Übersetzung Ratio	D1	D2	D3	D7	D11	D12	D15	D21	D22	D25	D31	D32
500	1 - 2	80 _{j6}	100 _{j6}	100 _{j6}	M20	250	345 ₁₇	85	200	345 ₁₇	105	200	345 ₁₇
	3 + 4	65 _{j6}						70					
	5 + 6	55 _{j6}											
Grösse Size	Übersetzung Ratio	L	L1	L2	L3	L7	L10	L12	L13	L14	L20	L22	L24
500	1 - 2	900	170	210	210	350	570	202	90	5	450	200	25
	3 + 4		140				540						
	5 + 6		110				510						
Grösse Size	Übersetzung Ratio	L30	L32	L34	L71	Passfeder D1 Keyway D1	Passfeder D2 + D3 Keyway D2 + D3						
500	1 - 2	450	202	23	285	22 x 14 x 160	28 x 16 x 180						
	3 + 4					18 x 11 x 125							
	5 + 6					16 x 10 x 90							

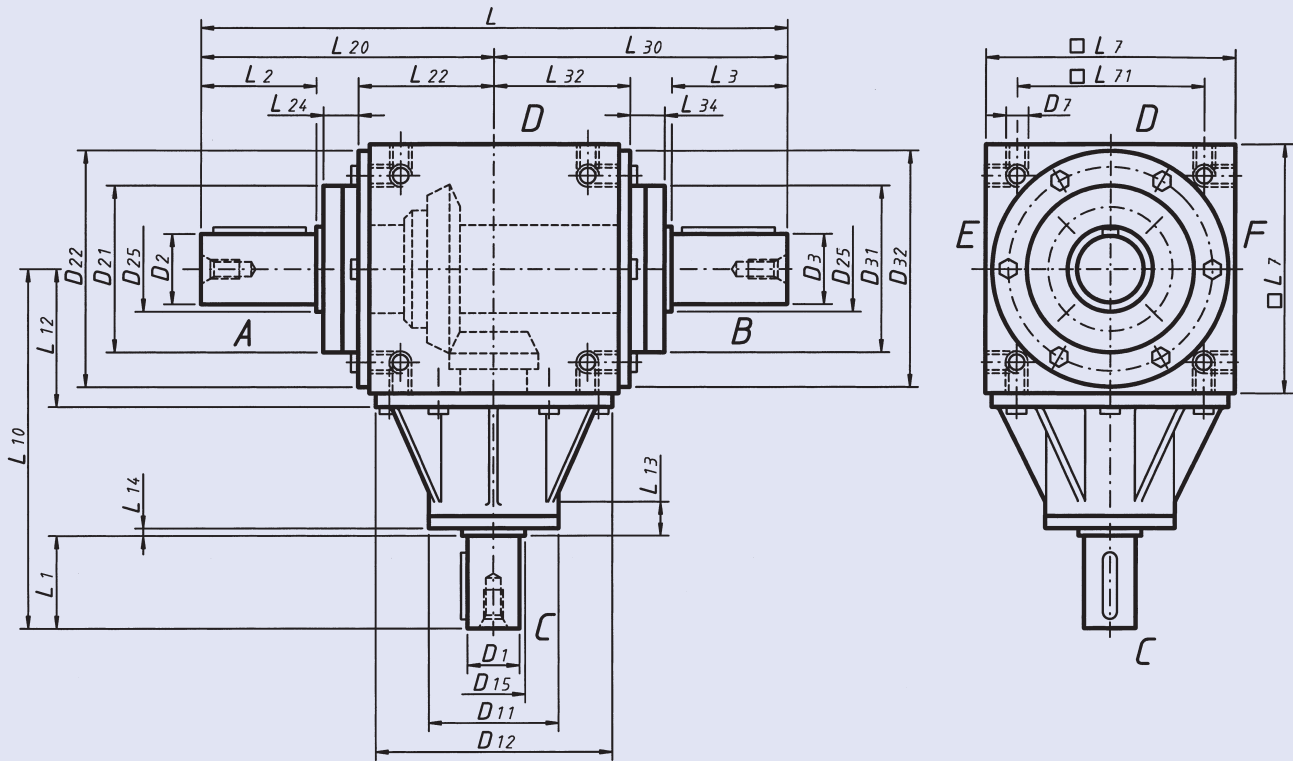

Bauarten / Design

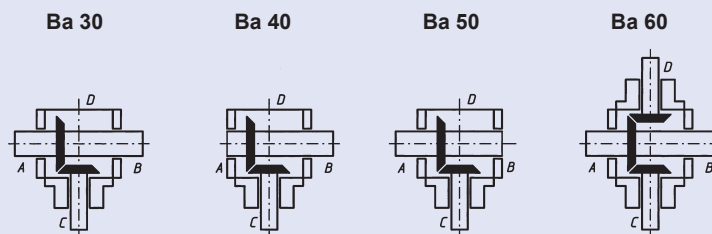

Hinweis:

Bei der Bauart 30 und 60 können über die durchgehende Welle (von A nach B) größere Drehmomente übertragen werden. (zul. Drehmoment 25 000 Nm). Die zul. Drehmomente der Kegelradsätze entsprechen dem Typ L.

Note:

The through shaft (A to B) on design 30 and 60 can transmit higher torques. (perm. torque 25 000 Nm). The permissible torque of the bevel gears is the same as type L.

Abmessungen Typ LV 600
Dimensions Type LV 600

Grösse Size	Übersetzung Ratio	D1	D2	D3	D7	D11	D12	D15	D21	D22	D25	D31	D32
600	1 - 2	90 _{j6}	140 _{j6}	140 _{j6}	M20	190	445 _{f7}	95	300	445 _{f7}	145	300	445 _{f7}
	3 + 4	75 _{j6}											
	5 + 6	60 _{j6}											

Grösse Size	Übersetzung Ratio	L	L1	L2	L3	L7	L10	L12	L13	L14	L20	L22	L24	
600	1 - 2	1040	150	200	200	450	600	250	33	5	520	245	70	
	3 + 4		120											570
	5 + 6		110											

Grösse Size	Übersetzung Ratio	L30	L32	L34	L71	Passfeder D1 Keyway D1	Passfeder D2 + D3 Keyway D2 + D3
600	1 - 2	520	245	70	360	25 x 14 x 140	36 x 20 x 180
	3 + 4					20 x 12 x 110	
	5 + 6					18 x 11 x 100	

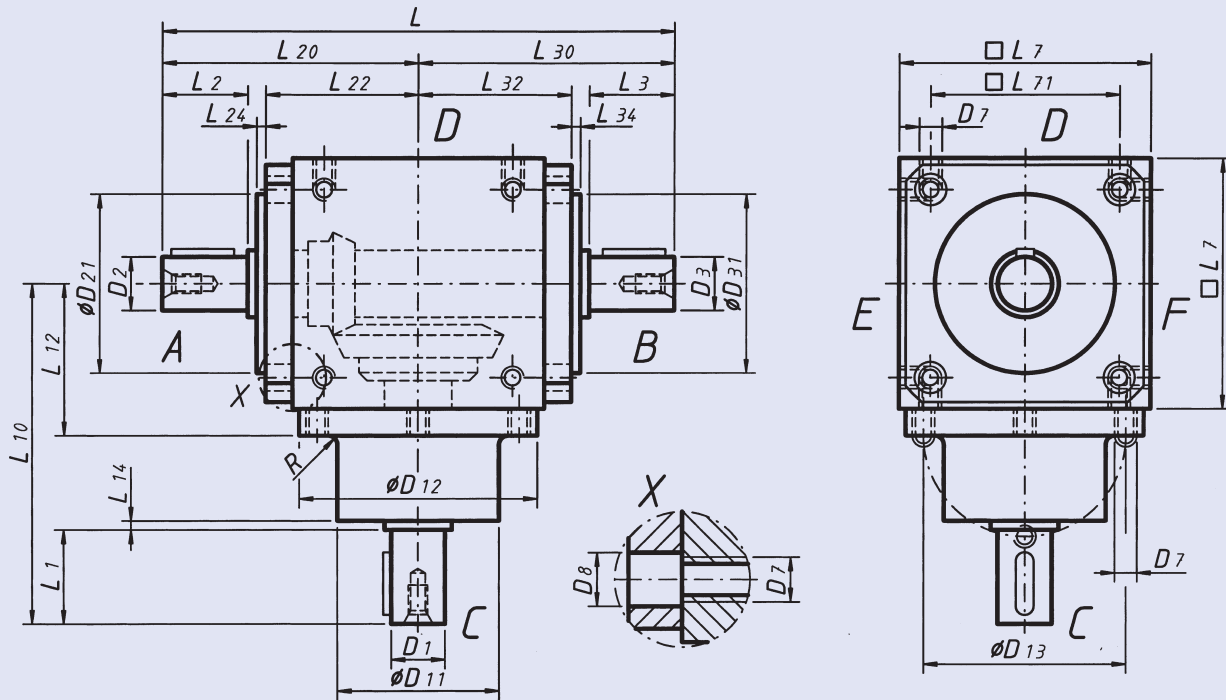

Bauarten / Design

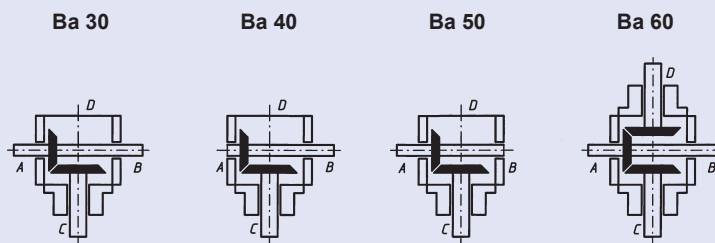

Achtung!

Bei Getriebe Typ LS ist zur Größenbestimmung die kleine Drehzahl und das große Drehmoment maßgebend.

Attention!

For size selection of gearbox type LS, the low speed and the high torque values are applicable.

Abmessungen Typ LS 100 - 400
Dimensions Type LS 100 - 400

Grösse Size	Übersetzung Ratio	D1	D2	D3	D7	D8	D11	D12	D13	D21	D31	L	L1	L2	L3
100	1,25	18 _{j6}	18 _{j6}	18 _{j6}	M8	9	60 _{f7}	89 _{f7}	75	60 _{f7}	60 _{f7}	190	35	35	35
	1,5 - 2		14 _{j6}	14 _{j6}											
200	1,25	25 _{j6}	25 _{j6}	25 _{j6}	M10	11	80 _{f7}	119 _{f7}	100	80 _{f7}	80 _{f7}	244	45	45	45
	1,5 - 2		16 _{j6}	16 _{j6}											
230	1,25	32 _{j6}	32 _{j6}	32 _{j6}	M10	11	95 _{f7}	135 _{f7}	115	100 _{f7}	100 _{f7}	274	50	50	50
	1,5 - 2		20 _{j6}	20 _{j6}											
250	1,25	35 _{j6}	35 _{j6}	35 _{j6}	M12	13,5	110 _{f7}	156 _{f7}	135	110 _{f7}	110 _{f7}	320	60	60	60
	1,5 - 2		25 _{j6}	25 _{j6}											
300	1,25	42 _{j6}	42 _{j6}	42 _{j6}	M12	13,5	120 _{f7}	198 _{f7}	175	120 _{f7}	120 _{f7}	406	80	80	80
	1,5 - 2		42 _{j6}	42 _{j6}											
370	1,25	55 _{j6}	55 _{j6}	55 _{j6}	M16	17,5	150 _{f7}	225 _{f7}	200	150 _{f7}	150 _{f7}	460	90	90	90
	1,5 - 2		45 _{j6}	45 _{j6}											
400	1,25	60 _{j6}	60 _{j6}	60 _{j6}	M16	17,5	160 _{f7}	258 _{f7}	230	180 _{f7}	180 _{f7}	570	110	110	110
	1,5 - 2		50 _{j6}	50 _{j6}								530		90	90

Grösse Size	Übersetzung Ratio	L7	L10	L12	L14	L20	L22	L24	L30	L32	L34	L71	R	Passfeder D1 Keyway D1	Passfeder /Key- way D3,D3
100	1,25	90	122	55	2	95	55	3	95	55	3	70	1	6 x 6 x 25	6 x 6 x 25
	1,5 - 2														5 x 5 x 25
200	1,25	120	162	75	2	122	72	3	122	72	3	100	1	8 x 7 x 36	8 x 7 x 36
	1,5 - 2														5 x 5 x 36
230	1,25	140	180	83	2	137	82	3	137	82	3	110	2	10 x 8 x 45	10 x 8 x 45
	1,5 - 2														6 x 6 x 40
250	1,25	160	212	95	2	160	95	3	160	95	3	120	2	10 x 8 x 45	10 x 8 x 45
	1,5 - 2														8 x 7 x 45
300	1,25	200	273	120	3	203	117	4	203	117	4	160	3	12 x 8 x 60	12 x 8 x 60
	1,5 - 2														12 x 8 x 60
370	1,25	230	305	135	2	230	132	6	230	132	6	180	5	16 x 10 x 80	16 x 10 x 80
	1,5 - 2														14 x 9 x 70
400	1,25	260	380	150	5	285	150	22	285	150	22	220	5	18 x 11 x 90	18 x 11 x 90
	1,5 - 2					265			265						14 x 9 x 70

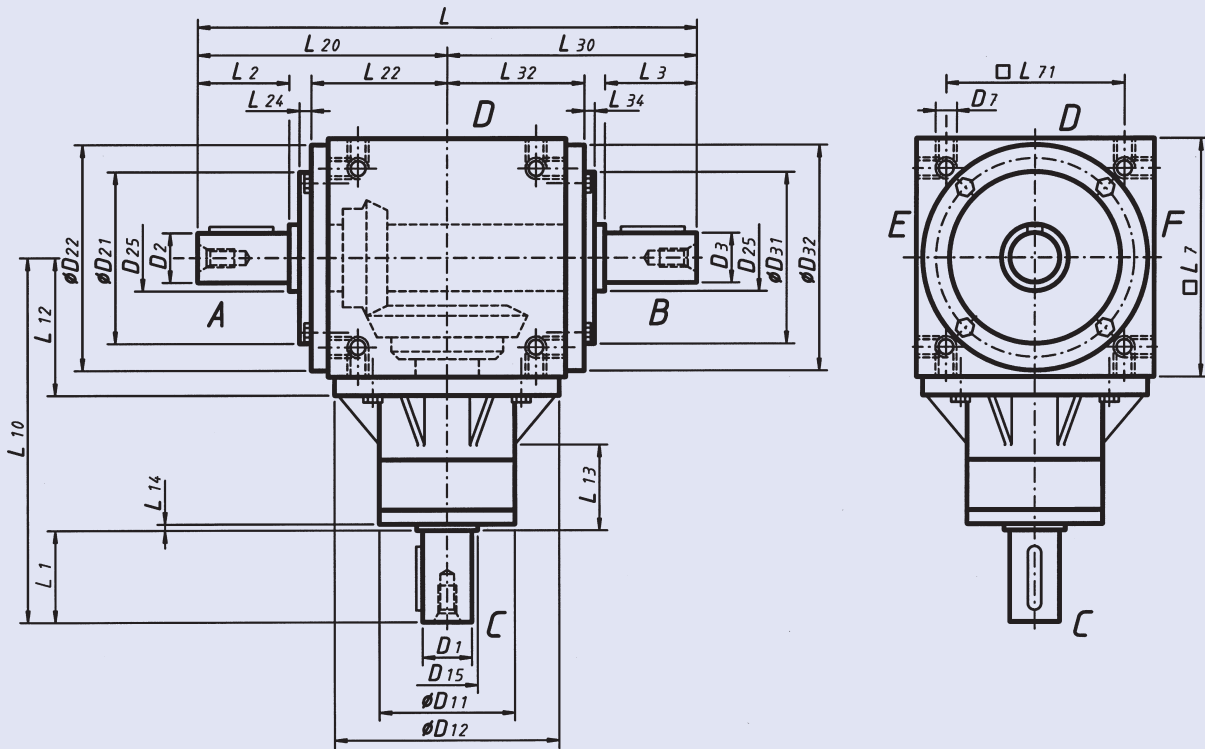

Bauarten / Design

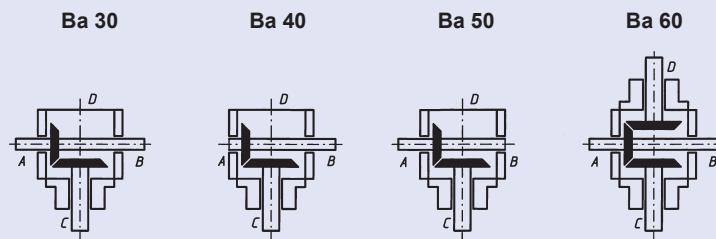

Achtung!

Bei Getriebe Typ LS ist zur Größenbestimmung die kleine Drehzahl und das große Drehmoment maßgebend.

Attention!

For size selection of gearbox type LS, the low speed and the high torque values are applicable.

Größe Size	Übersetzung Ratio	D1	D2	D3	D7	D11	D12	D15	D21	D22	D25	D31	D32	L	L1	L2	L3
500	1,25	80 _{j6}	70 _{j6}	70 _{j6}	M20	250	345 _{f7}	85	265	345 _{f7}	75	265	345 _{f7}	730	170	150	150
	1,5 - 2																

Größe Size	Übersetzung Ratio	L7	L10	L12	L13	L14	L20	L22	L24	L30	L32	L34	L71	Passfeder D1 Keyway D1	Passfeder /Key- way D3,D3
500	1,25	350	570	202	90	5	365	195	15	365	195	15	285	22 x 14 x 160	20 x 12 x 120
	1,5 - 2														

Typ / Type

- UL 1
- UL 2
- UL 25
- UL 30
- UL 4

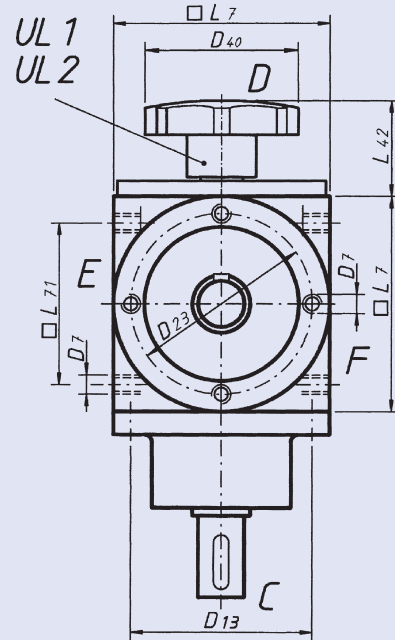
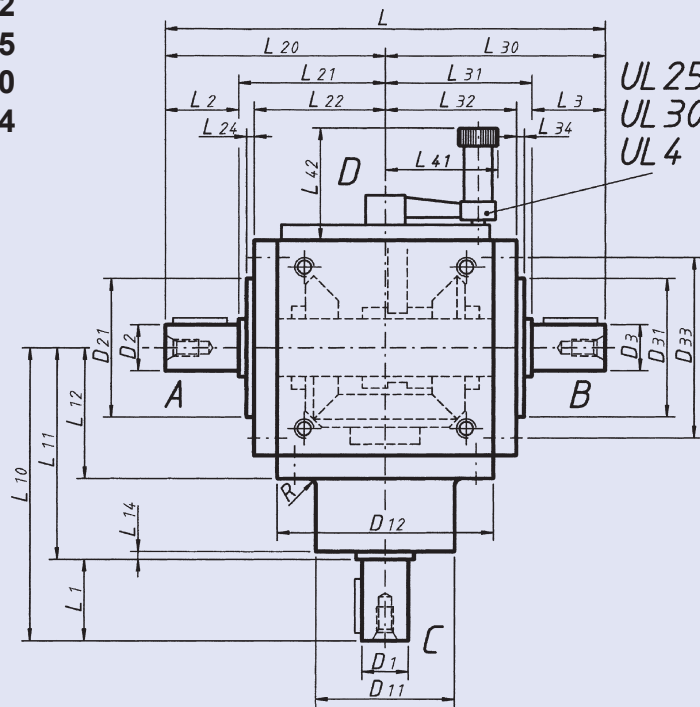

Typ / Type

- UL 23
- UL 37

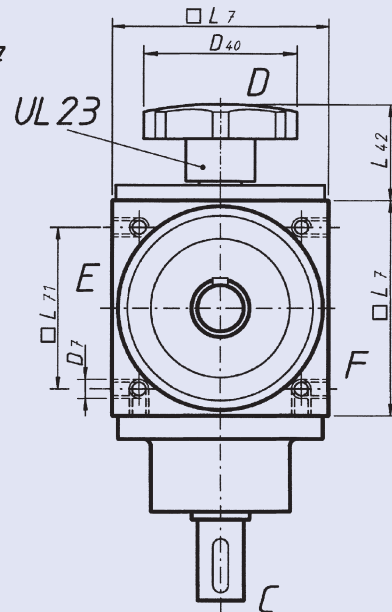
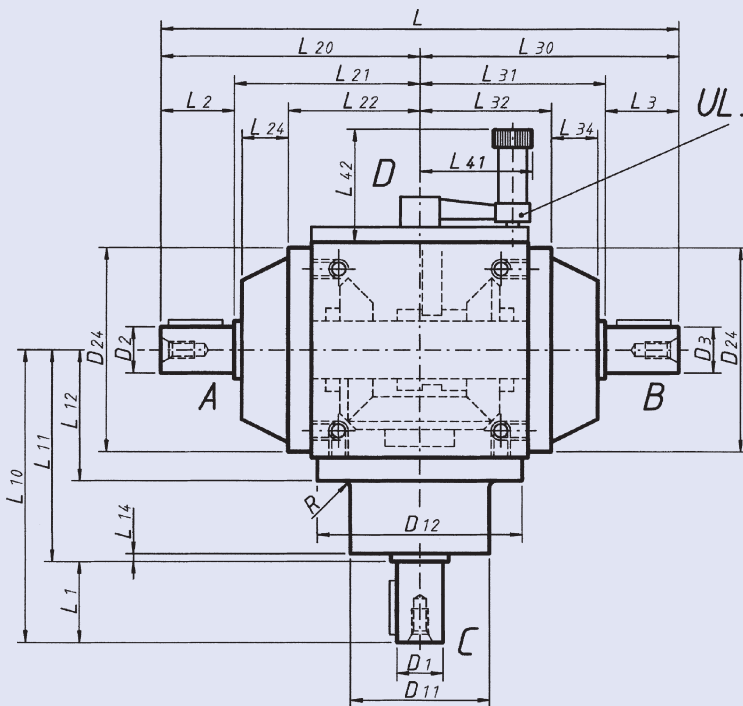

Abmessungen Typ UL

Dimensions Type UL

Ant

Grösse Size	Übersetzung Ratio	D1	D2	D3	D7	D11	D12	D13	D21	D23	D24	D31	D33	D40	L	L1	L2	L3	L7	L10
1	1 - 2	18 _{j6}	18 _{j6}	18 _{j6}	M8	60 _{f7}	90	75	90 _{f7}	-	-	90 _{f7}	-	80	206	35	35	35	90	122
2	1 - 2	25 _{j6}	25 _{j6}	25 _{j6}	M10	80 _{f7}	120	100	80 _{f7}	100	-	80 _{f7}	100	80	286	45	45	45	120	162
23	1 - 2	32 _{j6}	32 _{j6}	32 _{j6}	M10	95	135 _{h7}	-	-	-	135 _{h7}	-	-	100	340	50	50	50	140	180
25	1 - 2	35 _{j6}	35 _{j6}	35 _{j6}	M12	110 _{f7}	160	135	110 _{f7}	135	-	110 _{f7}	135	-	367	60	60	60	160	212
30	1 - 2	42 _{j6}	42 _{j6}	42 _{j6}	M12	120 _{f7}	200	175	120 _{f7}	175	-	120 _{f7}	175	-	406	80	80	80	200	273
37	1 - 2	55 _{j6}	55 _{j6}	55 _{j6}	M16	150	225 _{h7}	-	-	-	225 _{h7}	-	-	-	510	90	90	90	230	305
4	1 - 2	60 _{j6}	60 _{j6}	60 _{j6}	M16	160 _{f7}	260	230	180 _{f7}	230	-	180 _{f7}	230	-	600	110	110	110	260	380

Grösse Size	Übersetzung Ratio	L11	L12	L14	L20	L21	L22	L24	L30	L31	L32	L34	L41	L42	L71	R	Passfeder/Keyways	
																	d1	d2, d3
1	1 - 2	87	55	2	103	68	58	8	103	68	58	8	-	60	70	1	6 x 6 x 25	6 x 6 x 25
2	1 - 2	117	75	2	143	98	93	3	143	98	93	3	-	60	100	1	8 x 7 x 36	8 x 7 x 36
23	1 - 2	130	85	2	170	120	80	38	170	120	80	38	-	55	110	2	10 x 8 x 45	10 x 8 x 45
25	1 - 2	152	95	2	183,5	123,5	100	3	183,5	123,5	100	3	92	105	120	2	10 x 8 x 45	10 x 8 x 45
30	1 - 2	193	120	3	203	123	117	3	203	123	117	3	107	105	160	3	12 x 8 x 60	12 x 8 x 60
37	1 - 2	215	135	2	255	165	130	33	255	165	130	33	107	105	180	10	16 x 10 x 80	16 x 10 x 80
4	1 - 2	270	150	5	300	190	165	22	300	190	165	22	120	70	220	5	18 x 11 x 90	18 x 11 x 90

Bauarten / Design

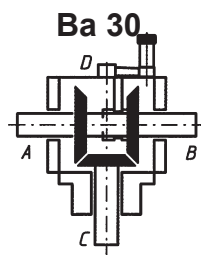

Schaltflanschanbau

Schaltflansch Seite D
Control lever side D

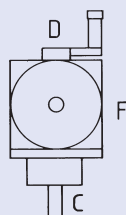

Position of control lever

Schaltflansch Seite E
Control lever side E

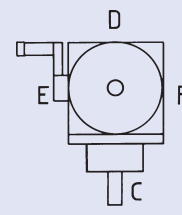

Schaltstellungen

Mittelstellung : Leerlauf
Links / Rechts: Drehrichtungsumkehr

Lever positions

middle position: neutral
Left / right : reversion of rotation

Antriebswelle D1 alle Typen

Input shaft D1 all types

Zul. Radialbelastung (Mitte Wellenzapfen) / Permissible radial load (middle of the shaft) [N]										
Antriebsdrehzahl [min ⁻¹] Input speed [rpm]	Getriebegröße / Gearbox size									
	50	100	200	230	250	300	370	400	500	600
10	550	880	1400	2050	3200	5800	11000	20000	40000	60000
50	550	880	1400	2050	3200	5800	11000	20000	40000	60000
100	450	700	1200	1750	2800	4800	8500	17500	34000	48000
250	350	570	880	1400	2100	3800	7000	15000	26000	38000
500	300	460	700	1100	1750	3100	6000	12000	21000	31000
750	270	430	650	1000	1650	2800	5100	10000	19000	28000
1000	250	390	600	950	1500	2600	4700	9000	18000	26000
1500	230	350	550	850	1300	2400	4200	8500	17500	24000
3000	170	280	440	690	1100	1900	3500	6800	15000	19000

Zul. Axialbelastung / Permissible axial load [N]										
Antriebsdrehzahl [min ⁻¹] Input speed [rpm]	Getriebegröße / Gearbox size									
	50	100	200	230	250	300	370	400	500	600
10	400	650	980	1500	2400	4000	7500	16000	29000	44000
50	400	650	980	1500	2400	4000	7500	16000	29000	44000
100	330	500	830	1250	2000	3400	6500	13000	24000	36000
250	260	400	650	1000	1550	2700	5000	9300	19000	28000
500	220	340	510	840	1300	2200	4100	8000	16500	24000
750	190	300	470	720	1150	2000	3800	7100	15500	22000
1000	170	280	430	680	1050	1800	3500	6500	14000	19500
1500	160	250	390	600	950	1600	3050	6300	12500	17500
3000	130	210	320	500	800	1650	2600	4800	9300	16000

Abtriebswelle D2 der Typen K, MK

Output shaft D2 type K, MK

Zul. Radialbelastung (Mitte Wellenzapfen) / Permissible radial load (middle of the shaft) [N]										
Abtriebsdrehzahl [min ⁻¹] Output speed [rpm]	Getriebegröße / Gearbox size									
	50	100	200	230	250	300	370	400	500	600
10	550	880	1400	2050	3200	5800	11000	20000	40000	60000
50	550	880	1400	2050	3200	5800	11000	20000	40000	60000
100	450	700	1200	1750	2800	4800	8500	17500	34000	48000
250	350	570	880	1400	2100	3800	7000	15000	26000	38000
500	300	460	700	1100	1750	3100	6000	12000	21000	31000
750	270	430	650	1000	1650	2800	5100	10000	19000	28000
1000	250	390	600	950	1500	2600	4700	9000	18000	26000
1500	230	350	550	850	1300	2400	4200	8500	17500	24000
3000	170	280	440	690	1100	1900	3500	6800	15000	19000

Zul. Axialbelastung / Permissible axial load [N]										
Abtriebsdrehzahl [min ⁻¹] Output speed [rpm]	Getriebegröße / Gearbox size									
	50	100	200	230	250	300	370	400	500	600
10	400	650	980	1500	2400	4000	7500	16000	29000	44000
50	400	650	980	1500	2400	4000	7500	16000	29000	44000
100	330	500	830	1250	2000	3400	6500	13000	24000	36000
250	260	400	650	1000	1550	2700	5000	9300	19000	28000
500	220	340	510	840	1300	2200	4100	8000	16500	24000
750	190	300	470	720	1150	2000	3800	7100	15500	22000
1000	170	280	430	680	1050	1800	3500	6500	14000	19500
1500	160	250	390	600	950	1600	3050	6300	12500	17500
3000	130	210	320	500	800	1650	2600	4800	9300	16000

Wellenbelastungen

Shaft loading

Abtriebswelle D2 / D3 der Typen L, ML, LS, UL

Output shaft D2 / D3 type L, ML, LS, UL

Zul. Radialbelastung (Mitte Wellenzapfen) / Permissible radial load (middle of the shaft) [N]										
Abtriebsdrehzahl [min ⁻¹] Output speed [rpm]	Getriebegröße / Gearbox size									
	50	100	200	230	250	300	370	400	500	600
10	900	1450	2200	3800	6500	10000	15500	27000	40000	70000
50	900	1450	2200	3800	6500	10000	15500	27000	40000	70000
100	750	1350	1850	3050	5100	8300	12500	22000	33000	60000
250	620	950	1500	2500	4000	6500	8700	18000	27000	46000
500	500	800	1250	2000	3400	5050	7500	15500	21000	38000
750	450	710	1150	1800	3000	4800	7000	14900	19000	35000
1000	400	680	1000	1650	2800	4300	6500	13000	18000	30000
1500	370	600	900	1500	2500	3900	6000	11000	17000	28000
3000	300	490	750	1250	2100	3200	4700	8500	15000	-

Zul. Axialbelastung / Permissible axial load [N]										
Abtriebsdrehzahl [min ⁻¹] Output speed [rpm]	Getriebegröße / Gearbox size									
	50	100	200	230	250	300	370	400	500	600
10	650	1000	1550	2650	4400	6900	10000	18000	28000	60000
50	650	1000	1550	2650	4400	6900	10000	18000	28000	60000
100	520	850	1300	2200	3700	5600	8500	16500	23000	48000
250	400	670	1000	1650	2800	4400	6500	12500	17500	38000
500	350	550	850	1400	2300	3700	5400	9800	16000	32000
750	310	500	750	1300	2150	3300	4900	9000	15000	29000
1000	280	450	700	1200	1950	3000	4500	8300	13000	26000
1500	260	400	650	1050	1700	2750	4000	7100	11500	24000
3000	210	330	520	840	1450	2250	3300	6500	9000	-

Abtriebswelle D2 / D3 der Typen H, MH, LV

Output shaft D2 / D3 type H, MH, LV

Zul. Radialbelastung (Mitte Wellenzapfen) / Permissible radial load (middle of the shaft) [N]										
Abtriebsdrehzahl [min ⁻¹] Output speed [rpm]	Getriebegröße / Gearbox size									
	50	100	200	230	250	300	370	400	500	600
10	1300	1900	3000	4800	8000	14500	18500	34000	50000	85000
50	1300	1900	3000	4800	8000	14500	18500	34000	50000	85000
100	1000	1550	2500	4000	6800	10500	16000	28000	43000	72000
250	780	1250	1900	3100	5200	8400	13000	22000	34000	58000
500	650	1000	1600	2600	4400	6900	9800	18000	28000	48000
750	600	900	1450	2300	4000	6400	8300	17500	25000	44000
1000	520	850	1300	2100	3600	6000	7900	16000	23000	40000
1500	480	750	1200	1900	3200	5000	7100	15000	20000	36000
3000	390	650	950	1550	2700	4200	6400	11000	17500	-

Zul. Axialbelastung / Permissible axial load [N]										
Abtriebsdrehzahl [min ⁻¹] Output speed [rpm]	Getriebegröße / Gearbox size									
	50	100	200	230	250	300	370	400	500	600
10	900	1500	2200	3800	6400	10000	15500	27000	40000	72000
50	900	1500	2200	3800	6400	10000	15500	27000	40000	72000
100	750	1250	1900	3050	5000	8400	12500	22000	33000	62000
250	600	950	1500	2400	4000	6500	8600	17500	26000	47000
500	500	800	1250	2000	3300	5100	7500	15500	21000	40000
750	450	740	1150	1750	3000	4900	7000	14500	19000	36000
1000	400	680	1000	1650	2700	4300	6500	12500	17500	33000
1500	370	600	900	1500	2600	4000	5600	11000	16500	30000
3000	300	480	740	1300	2050	3200	4700	8500	15000	-

Bei kombinierten Belastungen bitten wir um Rücksprache

Please contact us for combined load applications