

with tooth belt drive and integrated linear guide

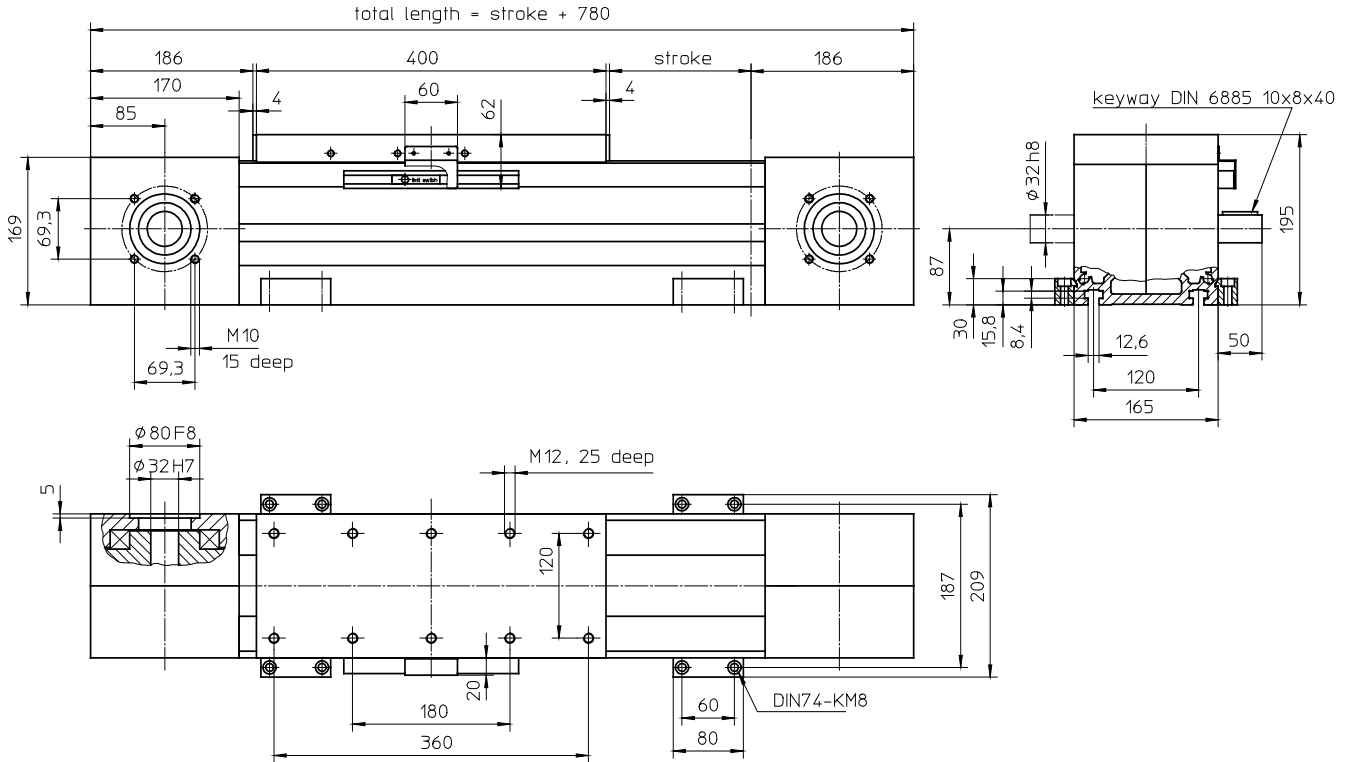

Weights

ZSS

Basic length, no stroke:	42.40 kg
100 mm stroke:	3.50 kg
Carriage:	11.90 kg
Mass inertia:	0.085 kgm ²

Technical data

Linear speed:	up to 8 m/s
Repeatability:	± 0.08 mm
Acceleration:	60 m/s ²
Idle torque:	12 Nm
Drive element:	tooth belt 75 AT 20
Stroke per revolution:	440 mm
Total length:	up to 7700 mm (longer on request)

Loads and load moments

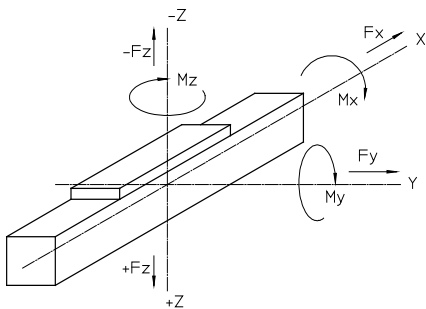

Type	with linear guide (ZSS)
Load	dynamic [N]
Fx	10000
Fy	5000
Fz	15000
-Fz	8000
Load moment	dynamic [Nm]
Mx	700
My	1400
Mz	1100