

Parallel gripper		Three-jaw gripper		<b>Angle gripper</b>		Internal-hole gripper		Other grippers		Electric gripper	
GZ8-16E	GZ8-16D	GZ11-18E	GZ18-23D	<b>GZ25-35E</b>	<b>GZ25-35G</b>	GZ25-35D	GZ55-65D				

- Sommer-automatic
- Grippers**
- Separators
- Swivel units
- Rotating jaws
- Axial compensators
- Tool changers
- Linear cylinders
- Shock absorbers
- Rotary cylinders
- Air vane motors
- Vacuum components
- Accessories
- Quick finder

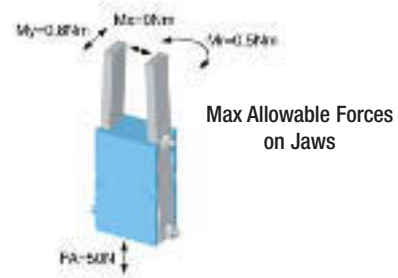

# Compliant finger gripper

Advantages, benefits, comparisons and tips!  
Stacks of information all about this product are on page 155.

Gripping force as a function of jaw length

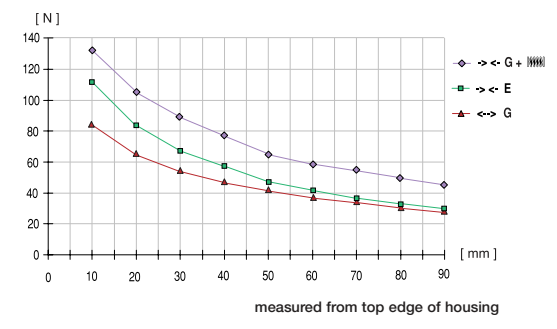

GZ25-35E

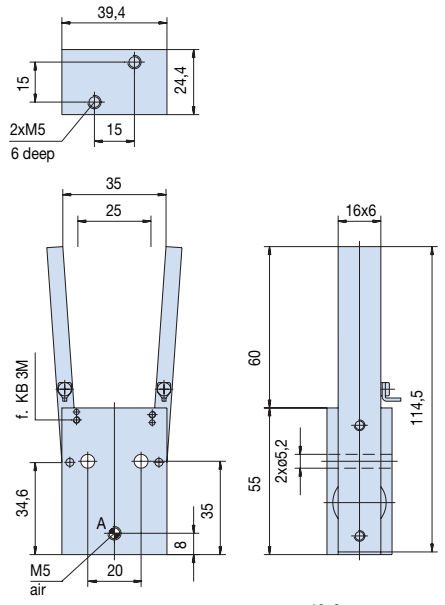

GZ25-35G

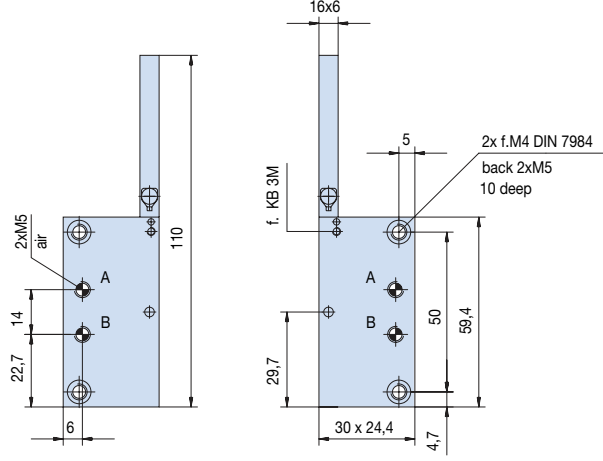

Order no.:		GZ25-35	GZ25-35				
E	G						
Drive:							
pneum.	pneum.						
Stroke per jaw [mm]:							
5	5						
Stroke per jaw [°]:							
4	4						
Gripping torque in closing [Nm]:							
4	5,4						
Gripping torque in opening [Nm]:							
-	3,4						
Self-locking via:							
Spring	Spring						
Closing time/opening time [s]:							
0,2/0,3	0,2/0,2						
Repeatability ± [mm]:							
0,1	0,1						
Min./max. operating pressure [bar]:							
5/8	4/8						
Air volume per cycle [cm³]:							
6	6						
Min./max. operating temperature [°C]:							
5/80	5/80						
Temp. resistant version up to 150° C [add to part number]:							
TS	TS						
Weight [kg]:							
0,253	0,313						

All data measured at 6 bar.

\* Measured at 10 mm from top edge of housing.

**See Page 155 for Accessory list.**