

Three-jaw long-stroke gripper with T-slot guide

Advantages, benefits, comparisons and tips! Stacks of information all about this product are on page 124.

Gripping force as a function of jaw length

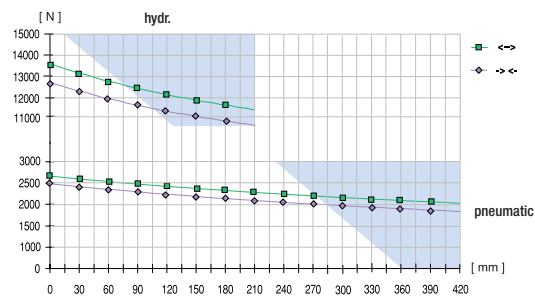

Colored area: increased wear and tear to be expected

Order no.:

GD560
- H

Drive:

pneum. hydr.

Stroke per jaw [mm]:

60 60

Gripping force in closing and opening [N]:

2480 12400

Self-locking via:

DSV 1/8 -

Closing time/opening time [s]:

0,45 0,8

Repeatability ± [mm]:

0,05 0,05

Min./max. operating pressure [bar]:

3/6 10/40

Air volume per cycle [cm³]:

650 -

Oil volume per cycle [cm³]:

- 650

Min./max. operating temperature [°C]:

5-80 5-80

Temp. resistant version up to 150°C [add to part number]

T6 T6

Piston diameter [mm]:

45 45

Weight [kg]:

29,0 29,0

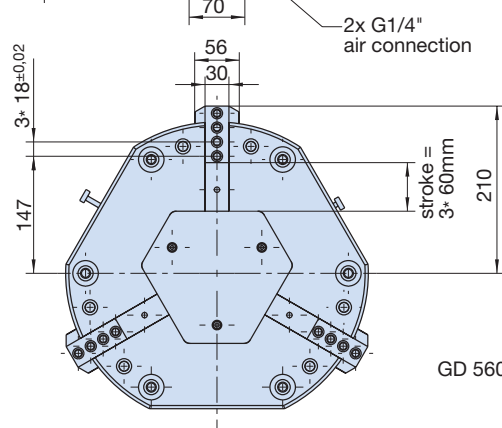
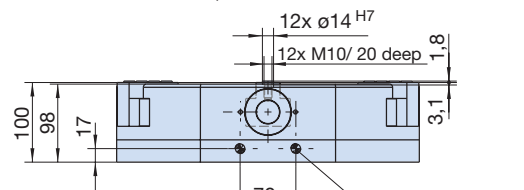
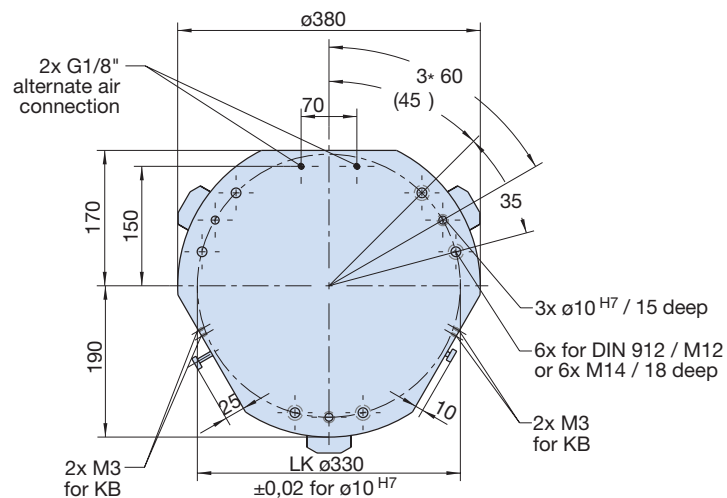
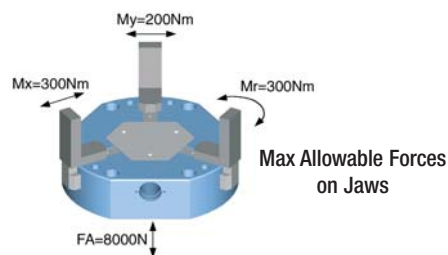
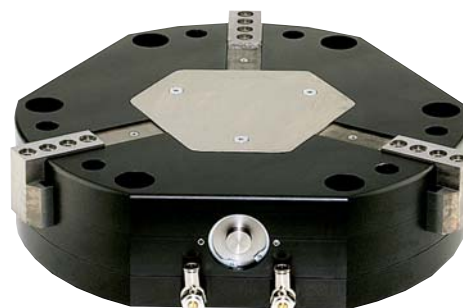

All data measured at 6 bar (hydr. 30 bar).

See Page 124 for Accessory list.