

Parallel gripper		Three-jaw gripper			Angle gripper	Internal-hole gripper	Other grippers		Electric gripper
GD304	GD306	GD308	GD310	GD312	GD316	GD320	Pressing star	Universal jaw	

Three-jaw gripper

with T-slot guide

Advantages, benefits, comparisons and tips!
Stacks of information all about this product are on page 103.

Gripping force as a function of jaw length

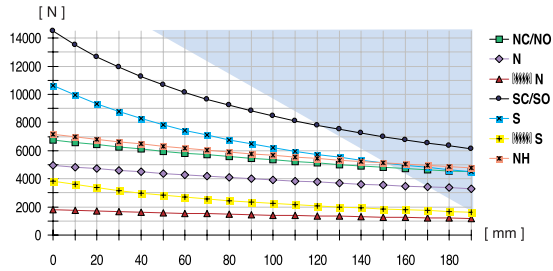

Colored area: increased wear and tear to be expected

Order no.:						
GD316	GD316	GD316	GD316	GD316	GD316	GD316
N	NC	NO	S	SC	SO	NH
Drive:						
pneum.	pneum.	pneum.	pneum.	pneum.	pneum.	hydr.
Stroke per jaw [mm]:						
16	16	16	8	8	8	16
Gripping force in closing and opening [N]:						
5000	-	-	10500	-	-	7000
Gripping force in closing [N]:						
-	6800	-	-	14100	-	-
Gripping force in opening [N]:						
-	-	6800	-	-	14100	-
Self-locking via:						
DSV1/8	Spring	Spring	DSV1/8	Spring	Spring	-
Closing time/opening time [s]:						
0,15	0,18	0,18	0,15	0,18	0,18	0,65
Repeatability ± [mm]:						
0,05	0,05	0,05	0,05	0,05	0,05	0,05
Min./max. operating pressure [bar]:						
3/8	5/8	5/8	3/8	5/8	5/8	10/40
Air volume per cycle [cm³]:						
395	783	783	395	783	783	-
Oil volume per cycle [cm³]:						
-	-	-	-	-	-	120
Min./max. operating temperature [°C]:						
5/80	5/80	5/80	5/80	5/80	5/80	5/80
Temp. resistant version up to 150° C [add to part number]:						
T2	T2	T2	T2	T2	T2	T2
Piston diameter [mm]:						
115	115	115	115	115	115	64
Weight [kg]:						
5,9	9,3	9,3	5,9	9,3	9,3	6,3

All data measured at 6 bar (hydr. 30 bar).

See Page 103 for Accessory list.

Pressing star available (see page 111).

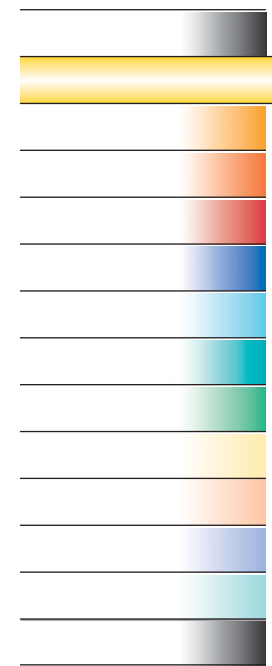
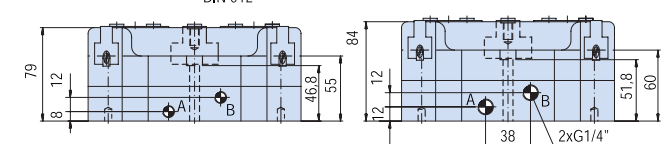
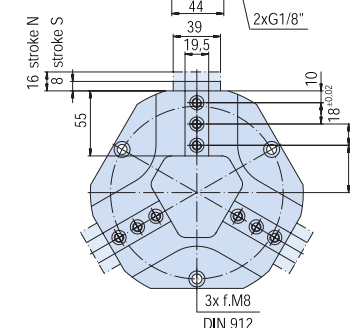
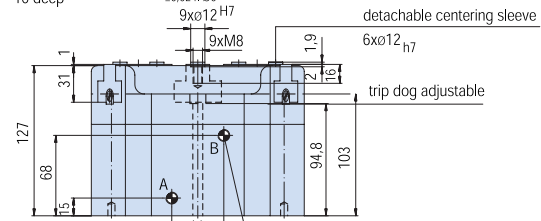
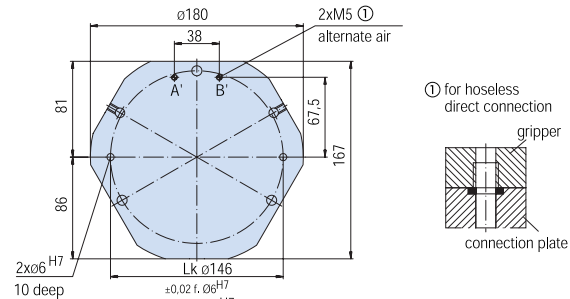
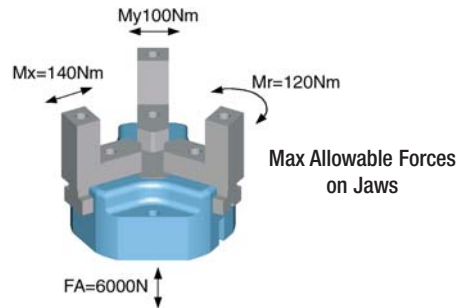

NC/NO

N/S

NH