

Backlash-free safety couplings

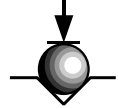

Series DXK/LO with keyway

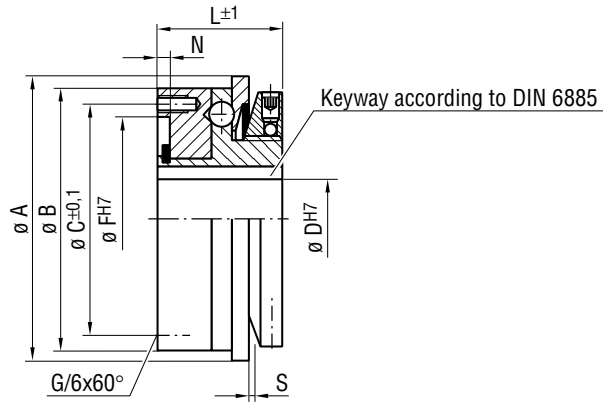

Technical data – series DXK/LO

TYPE		5	10	30	60	150	200	300	500
Disengaging torque adjustable	T_{KN} Version a	0.8–3	2–5	5–15	15–35	40–100	50–140	70–160	30–250
	T_{KN} Version b	3–5	5–10	10–30	20–70	70–150	100–200	150–300	200–500
Moment of inertia (10^{-3} Kgm ²)	J Hub side	0.04	0.07	0.2	0.5	1.2	2.8	4.5	6.5
	J Flange side	0.01	0.03	0.1	0.3	0.7	1.4	2.3	3.3
Weight (appr. kg)	m	0.12	0.17	0.35	0.7	1.1	1.7	2.2	2.7
Max. rotational speed (rpm)	n_{max}	15070	11450	9540	7530	6360	5450	4980	4580
Disengaging travel (mm)	s	0.6	0.7	1.2	1.2	2	2	2	2

Dimensions (mm) – series DXK/LO

TYPE		5	10	30	60	150	200	300	500
$\varnothing A$		42	50	65	74	90	110	120	130
$\varnothing B$		40	47	60	76	90	105	115	125
$\varnothing C$		33	42	53	69	80	90	102	112
$\varnothing D$		5–8	8–13	9–18	12–21	21–30	20–38	30–42	35–50
$\varnothing F$		28	37	47	62	68	80	90	100
$\varnothing G$	6 x thread / depth (mm)	M3/5	M3/5	M4/7	M5/8	M6/8	M6/10	M8/12	M8/12
L		19	22	28	36	38	42	47	47
N		2	2.5	3	4	4	4	5	5