

Backlash-free Safety Coupling Type DXK/ADS

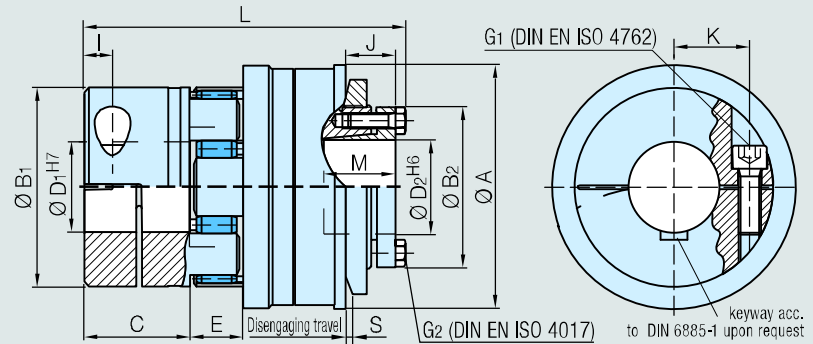

Technical data Type DXK/ADS

Type			14	19	24	28	38	42
Disengaging torque adjustable	(Nm)	TkN version a	2-5	5-15	12-35	25-75	70-160	90-250
		TkN version b	5-10	15-20 ¹⁾	30-70 ¹⁾	65-150	150-300	200-500
Moment of inertia	(10 ⁻³ kgm ²)	J Hub side	0,064	0,23	0,88	1,52	5,41	7,84
		J Elastomer side	0,006	0,036	0,15	0,33	1,04	3,1
Weight	(appr. kg)	m	0,28	0,58	1,1	1,7	3,7	4,4
Tightening torque of retaining screws	(Nm)	G1	5	10	18	43	84	145
		G2	3	5	8,5	14	18	25
Max. speed	(rpm)	n _{max}	11450	8950	7000	6000	5000	3600
Disengaging travel	(mm)	S	0,7	1,2	1,2	2	2	2
Spider shore hardness			98 SH A (red)					

Dimensions (mm) Type DXK/ADS

Type			14	19	24	28	38	42
L			66,5	88,5	111	123	151	170
A			50	65	80	95	119	130
C			11	25	30	35	45	56
→ D ₁ ^{H7}	min. - max.		9-14	10-20	20-28	24-35	32-44	40-60
→ D ₂ ^{H6}	min. - max.		8-16	12-20	12-25	21-35	30-45	35-50
K			10,5	15	20	24	30	40
E			13	16	18	20	24	28
I			5	6	10	11	13	15
G 1 (DIN EN ISO 4762)			M4	M5	M6	M8	M10	M12
G 2 (DIN EN ISO 4762)			6xM4	6xM4	6xM6	6xM6	6xM8	6xM8
B 1			30	40	55	65	80	105
B 2			34	41,5	50	62	76	85
J			15	16	17	20	26	26
M			16	20	25	30	35	38
Hub material		elastomer side	Al	Al	Al	Al	St	St

¹⁾ To obtain the maximum adjustment range for type b, use spider with 64Sh D. ²⁾ al = aluminum alloy, st = steel
A mechanical or electrical device sensing the position of the steel ring is necessary for torque limiters DMK/ADS (Disengaging travel). In case of overload the drive must be switched off.